



HISTORIC STRUCTURES REPORT THE FISHER MANSION



PREPARED BY:
Kent Brough
Soon-Ju Kwon
Shalae A. Larsen
Paul Nielsen
Sara Staffanson

PROFESSOR/ADVISOR:
Robert A. Young

UNIVERSITY OF UTAH
COLLEGE OF ARCHITECTURE +
PLANNING

TABLE OF CONTENTS

PART I - INTRODUCTION.....	4
PART II - DEVELOPMENTAL HISTORY.....	7
PART III - EXISTING CONDITIONS	
SECTION A - SITE & LANDSCAPE.....	10
SECTION B - FISHER MANSION	
First Floor.....	14
Second Floor.....	27
Third Floor.....	38
SECTION C - CARRIAGE HOUSE.....	43
PART IV - RECOMENDATIONS.....	46
APPENDIX A - BIBLIOGRAPHY.....	51
APPENDIX B - DRAWINGS.....	53
APPENDIX C - SUSTAINABILITY AND ENERGY EFFICIENCY CONSIDERATIONS.....	61

DISCLAIMER

This report was written in partial fulfillment of the course requirements for ARCH-6570 “Preservation Technology” offered by the University of Utah College of Architecture + Planning. This report is part of an academic exercise intended to provide the student with a “hands on” experience in historic preservation planning. *The building owner is advised that the recommendations proposed in this report must be validated as “appropriate” by a licensed architect, licensed engineer, or other accredited personnel prior to their implementation.*

In all cases the University of Utah, the College of Architecture + Planning, the personnel associated with the administration of this course, and the report authors shall be held harmless in any action concerning damage to the subject property and/or improvements as well as injuries to occupants based on the implementation of any portion of the material content of this report.

PART I

INTRODUCTION





1. Vicinity Map

STUDY SUMMARY

Research done to produce HSR

- Historical background research referencing newspaper articles primarily
- Several site visits throughout duration of project
- Interior evaluations completed on March 6th and 27th of 2008

Major research findings

- Home is in very good condition considering its age and various uses
- Some additions constructed over time
- Standard wear and tear throughout building

Major issues identified

- Immediate attention is required to stabilize the Carriage House, both inside and out

Recommendations for treatment or use

- Restore site and buildings to 1893 period of significance, in addition to rehabilitation of structure to accommodate proposed use.
- Add elevator to address accessibility issues
- Restore all interior surfaces
- Evaluate structure, plumbing, electrical, and HVAC for safety and code compliance
- Consider issues of sustainability

Project Data - General location information to identify building and property owner

Location:
1206 W. 200 S.
Salt Lake City, Utah

Contact person:
John Spencer
Salt Lake City Corporation
Property Manager
(801) 535-6398
john.spencer@slcgov.com

Proposed treatment of property

The future use of this property has not yet been determined. For the purposes of this report, it will be a restoration/rehabilitation treatment.

Cultural resource data

Named a Utah Historic Site in 1975 but not formally listed in the National Register because of the owner.

Related studies

Primarily Historical Backgrounds - Articles

Bash, J. (1993, October). *Albert Fisher Mansion observes its Centennial and Modern Purpose as Shelter for Homeless Men.* News Editor, p. 29.

Goodman, J. (1991, December 1). *West-side Mansion Nears Centennial.* The Salt Lake Tribune, p. E 13.

Goodman, J. (1993, July 25). *Carriage House Looks to New Lease on Life.* The Salt Lake Tribuen, p. E.2.

Hale, K. & Straube, M. (2008, January). *Albert Fisher Mansion- Built 1893.* A Salt Lake Solutions Project, p. 1-3.

Jensen, D. (2008, January 18). *Becker wants historic Fisher mansion, a 'hidden jewel,' open to public.* The Salt Lake Tribune, p. 1.

Page, J. (2008, February 9). *A Toast to historic S.L. Victorian.* Deseret Morning News, p. B.01.

PART II

DEVELOPMENTAL HISTORY





2. Albert Fisher and his wife, Alma, outside their home. Date unknown. Utah State Historical Society

Historical Background & Context

Albert Fisher immigrated from Seebach, Baden, Germany and came to Utah in 1881 where he began working as a foreman for the Salt Lake City Brewing Company. He later founded the A. Fisher Brewing Company in 1893. Fisher married Alma Young and together they had five children. He died in 1917, a few years before Prohibition wreaked havoc on brewery businesses.¹ Other buildings attributed to Fisher are the Hotel Albert (122 S. West Temple) and the Hotel Plandome (69-73 E. 400 S.).²

Fisher's mansion and adjoining carriage house, situated on the Jordan River Parkway, was built in 1893 at an estimated cost of \$13,000. Fisher chose the location because he was interested in living closer to his brewery, located to the north of the carriage house site.³

Richard K. A. Kletting, one of Utah's early distinguished architects who designed the Utah State Capitol Building in 1916, designed the mansion and carriage house. Exhibiting large scale and Victorian detailing common to this style of architecture, the home and carriage house also have some unique features that make it a "hidden jewel".⁴

The Fisher family occupied the home from 1893 until 1940 and managed the brewery until its closing. The home was then leased to the Catholic Church and became a convent for Our Lady of Victory Missionary Sisters, who used the facility through 1973. At that time, after purchasing the property, the Catholic Church remodeled the home and turned it into St. Mary's Home for Men. The new facility accommodated 41 residents and was a drug and alcohol-rehabilitation center, providing shelter, food, clothing, counseling and job assistance.⁵

With the development of the Jordan River Parkway, Salt Lake City purchased the site in 2006 in order to complete a segment of the parkway running to the north. In 2008, Mayor Ralph Becker named the property as his first Salt Lake Solutions project.⁶

- 1 Goodman, 1991.
- 2 Page, 2008.
- 3 Hale & Straube, 2008.
- 4 Jensen, 2008.
- 5 Bash, 1993.
- 6 Jensen, 2008.



3. Photo of the carriage house taken at the time of the HABS survey.

Chronology of Development & Use

The home was built in 1893 and constructed primarily using stone, masonry and wood. It is a combination of many styles. The curved bay windows and accompanying porch are Queen Anne in style, while the heavy masonry gives it a Romanesque appearance. The wooden spindled archways could be considered Eastlake in character.⁷ It maintained its original appearance until the building was sold to the Catholic Church in the 1970s. The additions to the northeast, northwest, and attic were likely made during the 1970s to accommodate its new use as a home for men. Remodeling in the kitchen was also likely completed during this time.

7 Goodman, 1991.

PART III

PHYSICAL DESCRIPTION

SECTION A

SITE & LANDSCAPE





3. Front-View of Main House and front-yard landscape taken from 200 South.



4. View of cross-shaped flower bed in front yard.



5. View of south-east stone spigot and weeping mulberry tree.

EXISTING SITE SURVEY:

Scale: nts

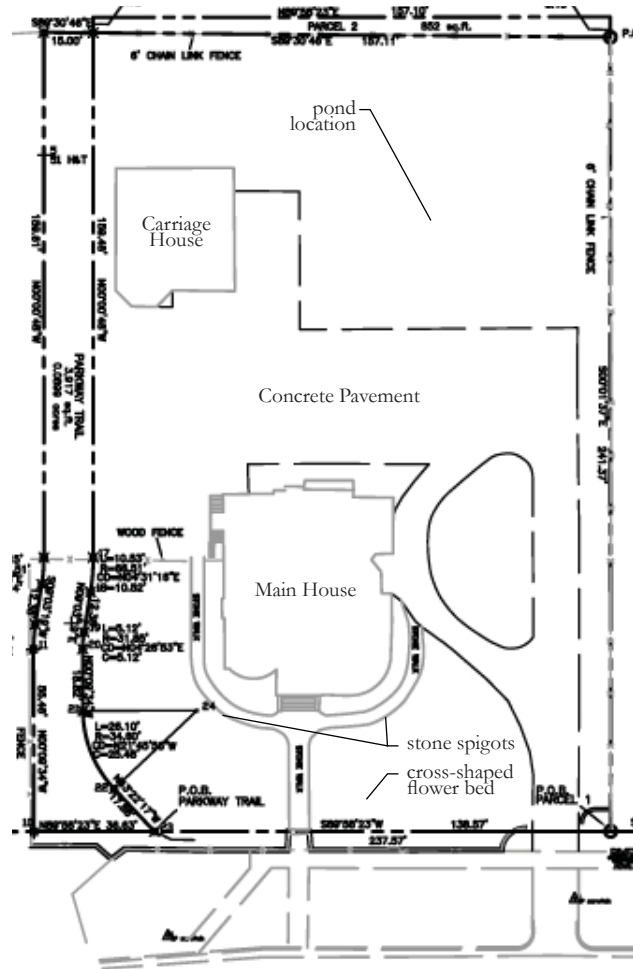

Over the years the landscape surrounding the Fisher mansion site has been modified to accommodate the changing use of the building. The original landscape was once typical of Victorian yards in the Salt Lake area. The landscape was originally designed with the purpose of showing off the architecture of the building, providing climate control for the structure, servicing functional uses for the owners, and for providing outdoor relaxation and recreation for the building's occupants. The aesthetic quality of the landscape would have originally focused on framing views into and out of the home. This can be seen in the formal entrance layout that features a wide sandstone walkway leading to the front porch (figure 3). The front-walkway and landscaping was primarily bilaterally symmetrical along the axis leading to the front doors. This symmetry was emphasized by the placement of two



6. North view of main house looking south, showing expansive paving in back-yard area.



7. Looking from driveway into north garden. View of orchard trees and fountain feature.



8. View of pond/fountain feature.



9. View looking west on the north side of the carriage house.

weeping mulberry trees and two stone spigots placed on either side of the walkway (figure 5). These features still exist today. The original drive access to the building would likely have consisted of concrete travel strips, macadam, or a compacted crushed stone. Photographic evidence and on-site archeological investigations may be used to determine the original layout and material quality of the original hardscape. Today a significantly larger concrete driveway exists, and was likely added to accommodate on-site parking (figure 6). The locations of paths around the building have also been altered as additions to the structure have changed the exterior circulation.

Hardscape – Existing original hardscape features include the main sandstone walkway approaching the primary entrance of the building; the retaining wall located along the south property line; and the ornamental iron fence attached to the top of the retaining wall (figure 3). New existing components include the concrete drive and parking, pond feature located in the north garden (figures E-F), the raised flower bed shaped like a cross in the south lawn, and the wood accessibility ramp located on the north-west corner of the building (figure 6). Other site features indicate original material that has been moved or altered, such as the sandstone walkway that wraps around the north-east corner of the building.

Plantings – Original plantings include large shade trees including American Elm (*Ulmus americana*), Boxelder (*Acer negundo*), Horse Chestnut (*Aesculus hippocastanum*), Linden (*Tilia sp.*), Silver maple (*Acer saccharinum*). Original fruiting and ornamental trees include Mulberry (*Morus alba*), Plum (*Prunus sp.*), Pear (*Pyrus sp.*), and Apple (*Malus sp.*). There is evidence of an original orchard on the northeast portion of the property (figure 7), along with a kitchen garden that appears to have been located behind the carriage house (Figure 9). More recently evergreen trees including Spruce (*Picea sp.*) and Arborvitae (*Thuja sp.*) have been planted in the south front-yard and north-east portions of the property. This includes the placement of two spruce trees that are located too close to the foundation on either side of the front-porch steps (figure 3).

Infrastructure – The existing irrigation system consists of hose bibs. During the summer months maintenance staff irrigate by dragging hoses around the site.

PART III

PHYSICAL DESCRIPTION

SECTION B

MAIN BUILDING



EXISTING CONDITIONS FLOOR PLAN:

Scale 1" = 200'

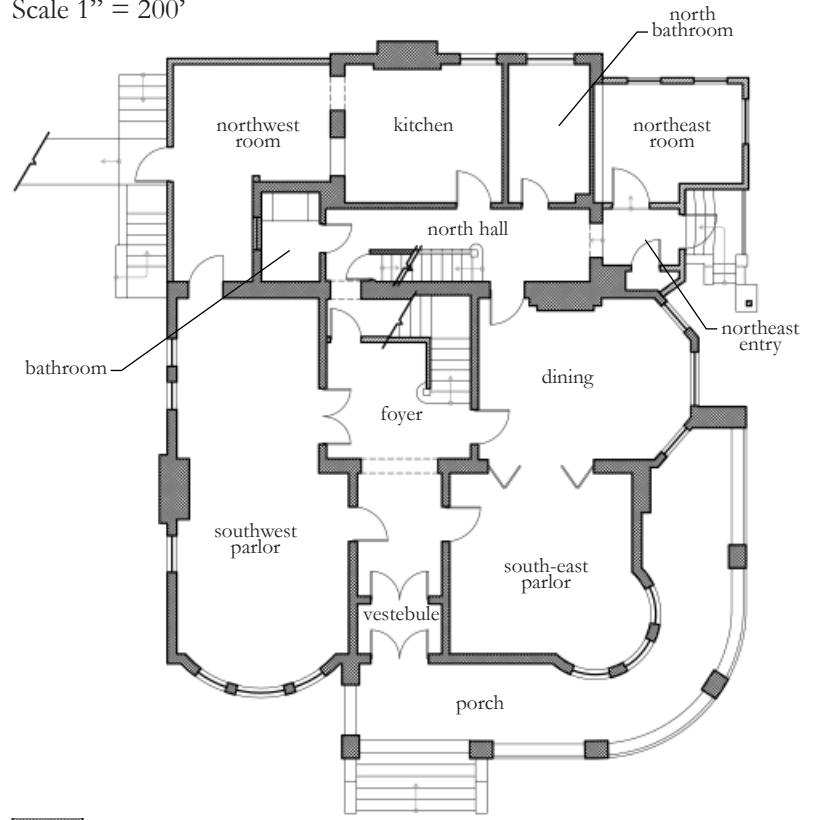

ORIGINAL WALLS

CHANGED WALLS

The following section describes the existing condition of the Main Level. A summary of main-level conditions includes:

- The original floor plan is largely intact. Some walls have been added to create or subdivide rooms.
- The original woodwork, doors, windows, and door hardware are intact and in good condition.
- Wall surfaces have several layers of paint and wall paper. There is evidence of plaster damage in the southwest parlor ceiling and the north hall ceiling. New drywall exists on changed walls.
- The floor surfaces throughout consist of carpet and tile, additional layers of flooring exist underneath some surfaces and include linoleum.



10.



SOUTH-EAST PARLOR

Floor – The floor surface is carpet over pre-existing linoleum. There may be additional layers of flooring (possibly wood) underneath. It is possible that the linoleum could have been an original finish floor surface based on the period of the home.

Walls – The original wood wainscoting is intact. Its condition is fair with some scratches, and the baseboard is heavily scuffed. Above the wainscoting the wall surface is painted over embossed paper. Samples would have to be removed to determine the total layers of wall surface, and what the original wall surface would have been.

Ceiling – A fire protection system has been added to this room and visible pipes and sprinkler heads hang just below the ceiling surface.

Doors & Windows – The room has three windows located in a curved bay in the southeast corner of the room. The windows are curved to match the curvature of the bay. The hardware and cords appear to be intact except the middle window that is missing its pulleys. The pulleys may have been removed, or simply covered over. All the doors and door hardware are intact and in good condition.

Fireplace – A chimney is located on the east wall, but the fireplace that once existed has been removed. The interior does not indicate the presence of a chimney. A built-in



11.



12.



13.

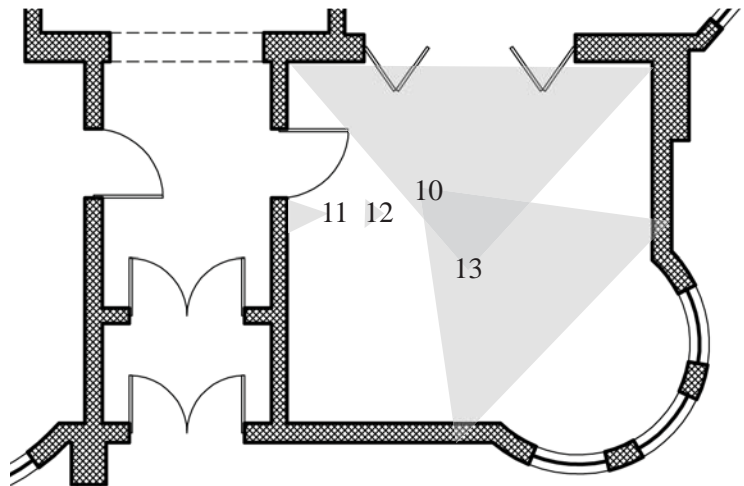



14.

cabinet has been added where the chimney would have stood.

Other Notes - At some point a wall dividing the room had been added and has since been removed. This is visible in the layers of wall paint and flooring surface that indicate the position of the wall.



15.



DINING ROOM

Floor - The floor surface is carpet over pre-existing linoleum. There may be additional layers of flooring (possibly wood) underneath. It is possible that the linoleum could have been an original finish floor surface based on the period of the home.

Walls - The original wood wainscoting is intact. Its condition is fair with some scratches, and the baseboard is heavily scuffed. Above the wainscoting the wall surface is painted over an embossed paper. Samples would have to be removed to determine the total layers of wall surface, and what the original wall surface would have been.



16.

Ceiling - A fire protection system has been added to this room and visible pipes and sprinkler heads hang just below the ceiling surface.

Doors & Windows - The room has three windows located on the east wall. All three windows have a bottom sash that is operable. The upper sash appears to be a fixed transom. All the doors and door hardware are intact and in good condition.



17.

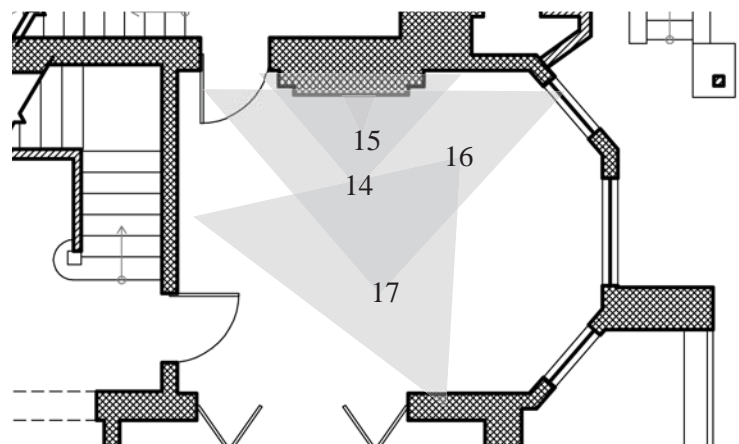



18.

Other notes – This room has a fireplace located on the north side of the room. The chimney protrudes into the room several inches and is covered in the same wall covering as the rest of the room. The fireplace mantle is wood and is in fair condition with noticeable scratches and dents in the finish. The tile surround appears to be original hand-glazed ceramic tile with an earth-tone glaze and decorative sculptural relief. Several of the tiles are cracked but in stable condition. The condition of the chimney flue is unknown, and should be inspected prior to use.



VESTIBULE



19.

Floor – The floor surface of the entry is covered in decorative tile work, which appears to be original, and is in good condition.

Walls – The original wood wainscoting is intact. Its condition is fair with some scratches, and the baseboard is heavily scuffed. There is evidence of water damage along some of the baseboards where snow and water from shoes has collected.



20.

Doors & Windows – The double-entry doors are wood, with beveled glass in the upper panels. They appear to be original and are in good condition. The interior double doors are also wood with larger areas of glass. These doors mimic the character and design of the entry doors. Both sets of doors appear to be original and in good condition. The doors appear to have their original hardware, including a unique lockset and matching hinges, which were designed with a unique metal scrollwork pattern. Transoms are located above each set of doors.



21.

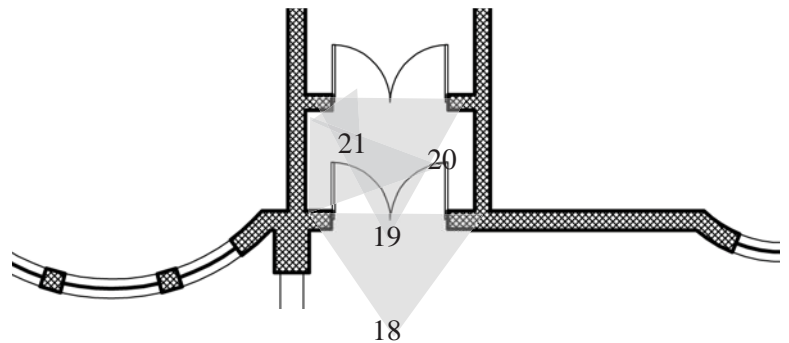



22.



FOYER

Floor - The floor surface is carpet over pre-existing linoleum. There may be additional layers of flooring (possibly wood) underneath. It is possible that the linoleum could have been the original finish floor surface, as this material was readily available when the home was originally constructed.

Walls - The original wood wainscoting is intact. Its condition is fair with some scratches, and the baseboard is heavily scuffed. Above the wainscoting, the wall surface is painted over some type of embossed paper. Samples would have to be removed to determine the total layers of wall surface, and what the original wall surface would have been.

Ceiling - A fire protection system has been added to this room and visible pipes and sprinkler heads hang just below the ceiling surface.

Doors & Windows - Aside from the transom located off the interior entry doors, the room has no windows. All the original doors and hardware appear to be intact and in good condition.



23.



24.

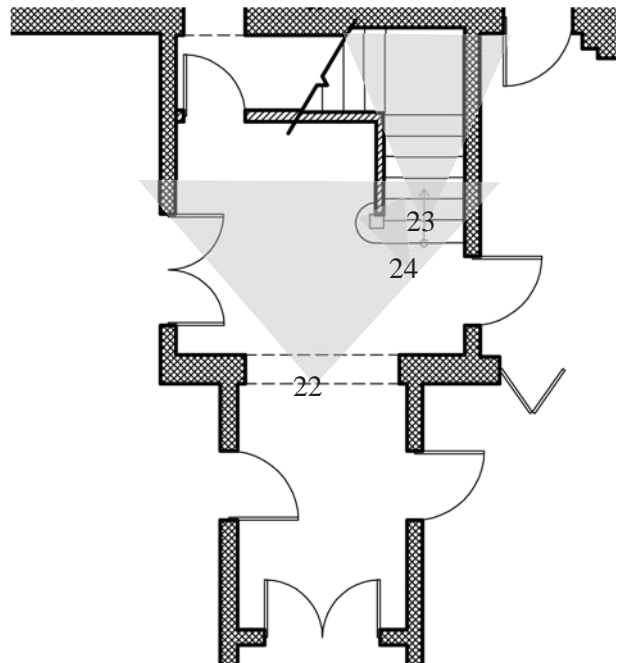

Other – The foyer opens up onto the staircase. The balustrade and stairwell opening have been enclosed by gypsum wallboard. The original carved wood newel post is intact and in good condition. A hole on the top of the newel post, suggests that a light fixture was mounted on top of the post at some point in time, and has since been removed. The wood stair treads and risers appear to be original and in good condition.



25.



26.



SOUTHWEST PARLOR

Floors – The floor surface is covered in a modern porcelain tile. It is not possible to see what layers of floor covering may be located underneath the tile.

Walls – The wall surface is painted over some sort of textured surface. It is unclear as to whether this surface was a papered surface as in the other rooms or an intentional gypsum wallboard texture that may have been added to disguise plaster repairs. This room lacks the wainscoting that is present in the other rooms. The wood trim matches the profile of the woodwork in the other rooms, but is painted in some kind of decorative finish that mimics the look of fine grained woodwork.

Ceiling – The ceiling is coved, continuing the same wall surface as previously described. There are significant signs of plaster damage just below the surface. A fire protection system has been added to this room and visible pipes and sprinkler heads hang just below the ceiling surface.

Doors & Windows – The room has three large south-facing windows. The center of these windows consists of one large sash with a fixed transom above. The sash appears to be operable, but there are no pulleys or signs of pre-existing pulleys. The two side windows are double hung sashes with a fixed transom above. These windows have a type of pulley that uses a spring-loaded metal tape instead of a cord and weight system.

The room also has three east facing windows; two located to the south of the fireplace and one located to the north of



27



28.

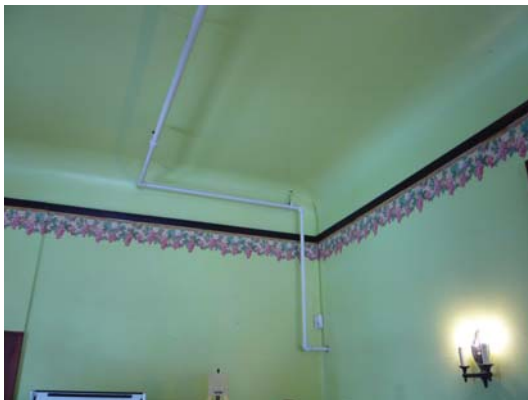

29.

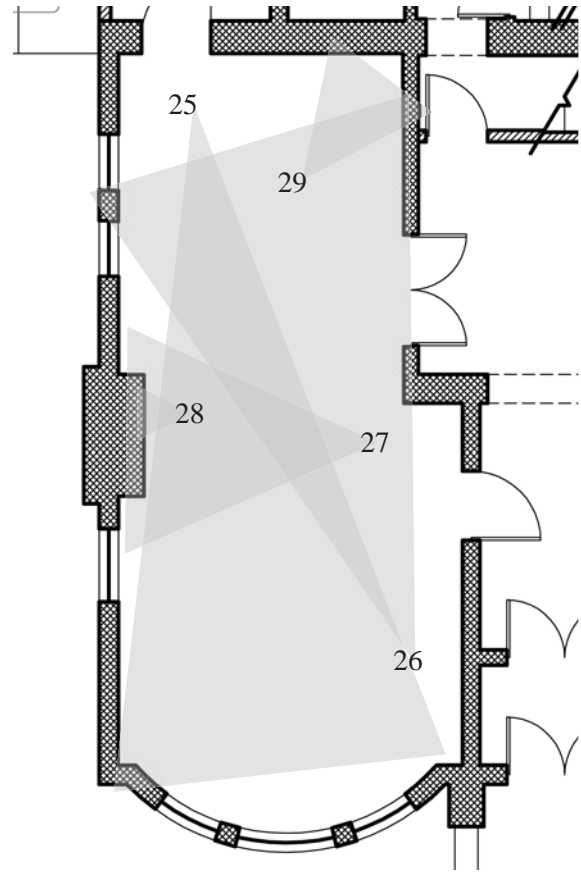

the fireplace on the west wall. These windows are the same form as the two smaller windows on the south wall. The window located closest to the chimney on the south side is missing an upper sash where an air conditioning unit is now located.

The doors and door hardware appear to be original and in good condition, except the north passage door which is new. This door would have originally accessed the back-porch, which has been enclosed. The door opening has been framed in, covering the original transom and decreasing the size of the door. A newer door and trim currently exist.



30.



31.



32.



NORTHWEST ROOM

Floor – The same tile floor surface as described in the Southwest Parlor continues into this room. It is not possible to discern what the original flooring surface was.

Walls - The newer north and west walls are finished in gypsum wallboard. The thickness of these walls and the finish surface indicate that they are wood-framed. The east and south walls in the room are brick, and were at one time the exterior walls of the home. The brick on these walls is still exposed and in good condition.

Doors & Windows – The room has two original exterior windows and two exterior door openings, on the south and east walls. One window has been covered over, while both doors are being used as passageways to and from the adjoining rooms. The window sashes and frames have been removed.

General Notes – As previously mentioned, this room was originally a back porch, as is visible from the exterior brick wall located on the east and south walls of the room.

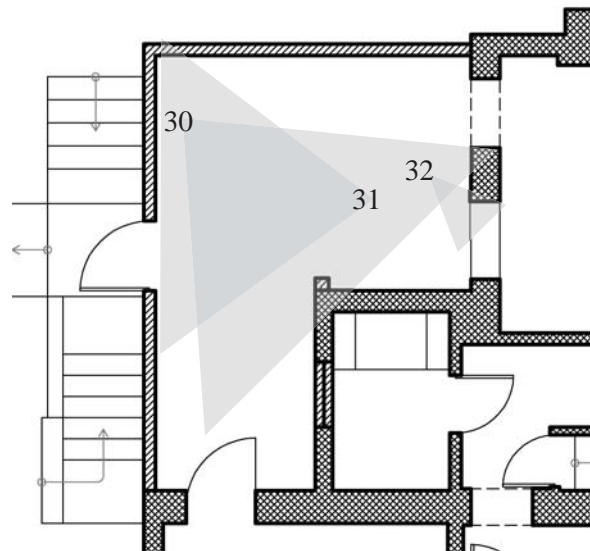



33.



KITCHEN

Floor – The same tile floor surface as described in the south-west parlor, and north-west room continues into this room.

Walls – The east wall appears to be either a new or partially new wall, as is indicated by the baseboard that stops abruptly at the corners where the north and south walls intersect the east wall. There is however existing plumbing in this wall, which indicates it may be original. Possible explanations for the corner conditions could include re-surfacing of the east wall. Further investigation of this wall may reveal the room’s original layout.

Fireplace – A chimney is located on the exterior of the north wall, but the stove that once existed has been removed. The wall extrudes slightly where a fireplace once stood.

Ceiling – The ceiling in this room has been dropped using a modern grid and panel system.

Doors & Windows – The room has a single window on the east side of the north wall. The original double-hung window is missing the upper sash. The original pulleys are intact, but the cords are missing.



34.



35.

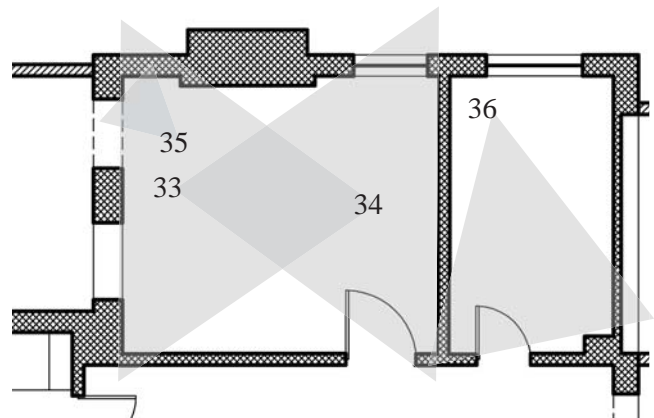



36.



NORTH BATHROOM

Walls – As previously described in the kitchen assessment, it is possible that this room was created by adding a wall to the original kitchen. The interior walls are partially covered by bathroom fixtures and porcelain wall tile. And restroom partition walls have been added to divide off the bathroom stalls.

Doors & Windows – The room has a single window on the east side of the north wall. The window is a newer aluminum window. The room has a single door on the south wall that is smaller in scale than the rest of the doors in the house. The door has been trimmed in newer, smaller, and simpler trim. This indicates that this door, and possibly the opening itself are not original.

Floor – The floor is vinyl.

Ceiling – The ceiling in this room has been dropped. The ceiling material appears to be gypsum wallboard.



37.



NORTHEAST ENTRY

The northeast vestibule was originally an exterior portion of the home. The original porch or stoop has been enclosed creating a small entry space.

Walls - The west-wall of the space is the original exterior of the building. The brick surface is exposed and in good condition.

Floor – The floor is composed of tile with a Native American motif.

Doors – The east door is newer with modern trim. The west door is the original exterior door and opening.

The northeast addition is accessed off of the northeast vestibule. This room is an addition to the original structure.



38.

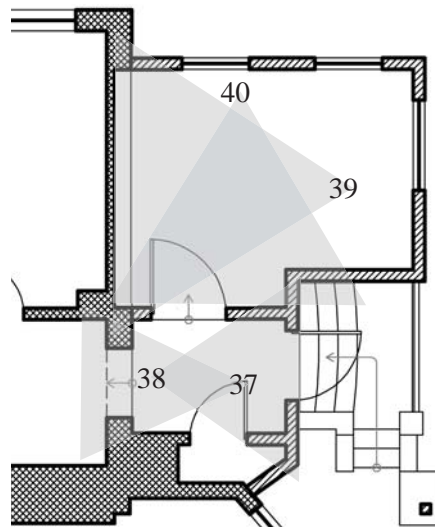

39.



40.



NORTHEAST ADDITION

Walls - The walls in this room are painted gypsum board, most likely over wood framing. The west wall is gypsum which has been applied over the original exterior brick wall.

Floor - The flooring in this room is carpet

Doors and Windows - The windows are aluminum sliders. The door and casement is modern.



41.



NORTH HALL

Floor – The floor surface is carpet over pre-existing linoleum. There may be additional layers of flooring (possibly wood) underneath. It is possible that the linoleum could have been an original finish floor surface based on the period of the home.

Walls – The original wood wainscoting is intact. Its condition is fair with some scratches, and the baseboard is heavily scuffed. Above the wainscoting the wall surface is painted over a paper-like material. It is likely anaglypta, Lincrusta, or other wallpaper. Samples would have to be removed to determine the total layers of wall surface, and what the original wall surface would have been.

Ceiling – The ceiling surface appears to be a newer surface applied over the older surface, possibly to disguise water damage from the second floor bathrooms. A fire protection system has been added to this room and visible pipes and sprinkler heads hang just below the ceiling surface.



42.

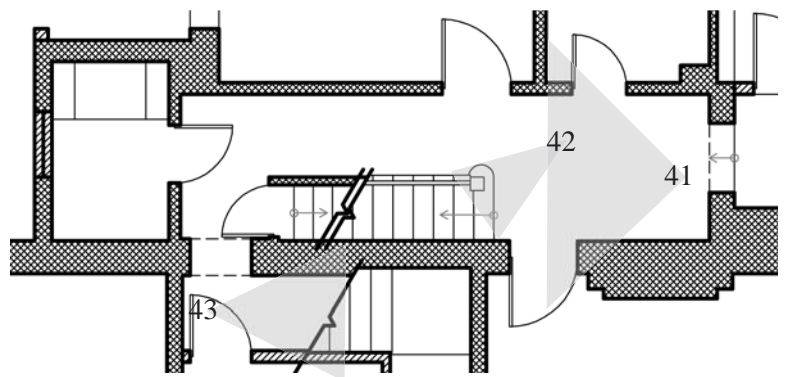



43.

Closet Under Stairs -

Original doors/woodwork/wainscot/hardware. Evidence of re-plastering under stair/ceiling

General Notes – This room is circulatory in nature, providing access to the home’s secondary staircase. The wood staircase, newel post, and balustrade are original and in good condition.



44.



BATHROOM

Floor – The floor is made up of a tile surface. There is damage behind the toilet, under the sink, and below the shower.

Fixtures – The sink is original, but the toilet and shower are new.

Wall – The walls maintain their original plaster and are in good condition. There is some damage above the toilet.

Doors and windows – The room has one door and one window. The window has been covered over from the outside and the sashes and lites have been painted over.

General Notes – This bathroom appears to be original to the home, with the exception of a newer shower system that has been added, partially covering the window.

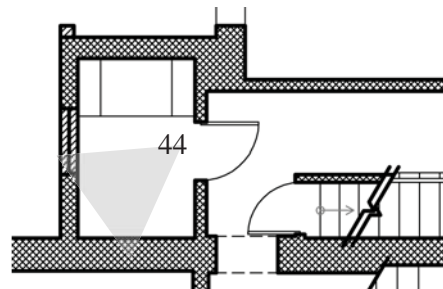

EXISTING CONDITIONS FLOOR PLAN:

Scale 1" = 200'

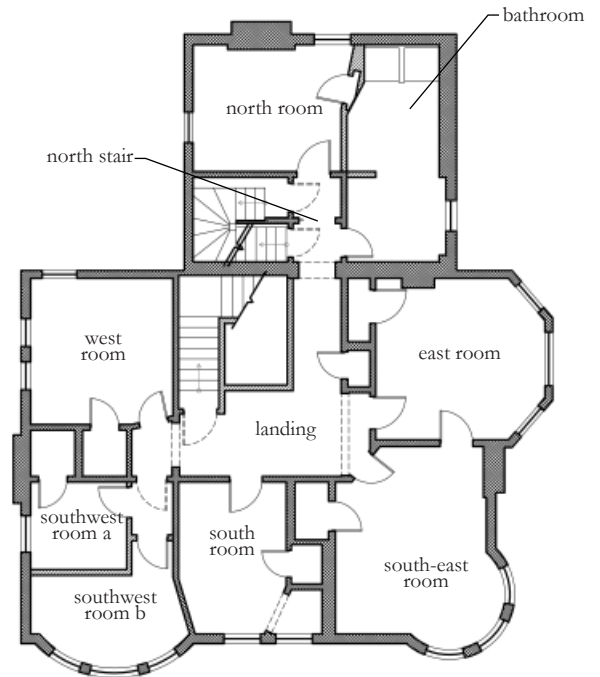

ORIGINAL WALLS



CHANGED WALLS

The following section describes the existing condition of the second level. A summary of second level conditions includes:

- The original floor plan is largely intact. Some walls have been added to create or subdivide rooms.
- The original woodwork, doors, windows, and door hardware are intact and in good condition.
- Wall surfaces have several layers of paint and wall paper.
- The floor surfaces throughout the second level consist of some species of wood flooring - possibly oak. The flooring is in reasonably good condition, with scratches and dents.



45.



WEST ROOM

Floor- The floor surface is original hardwood flooring. The floor is in poor condition with many scratches and nicks throughout the room.

Walls- The original wood wainscoting is intact. Its condition is fair with some scratches, and the baseboard is heavily scuffed. Above the wainscoting the wall surface is painted over a paper-like material. Samples would have to be removed to determine the total layers of wall surface, and what the original wall surface would have been.

Ceiling- A light fixture has been added to this room.

Doors & Windows- The room has three windows with two located in the west wall and one located in the north wall. The hardware and cords appear to be intact. All the doors, transoms, and hardware are intact and in good condition.

General Notes- Overall, this room has maintained its original condition.

Northwest Bedroom Closet -

Floor- The floor surface is vinyl over the original hardwood flooring. The vinyl flooring is in poor condition.

Walls- The original wood wainscoting is intact. It has been painted over with a light blue color as well as the wall surfaces.



46.



47.

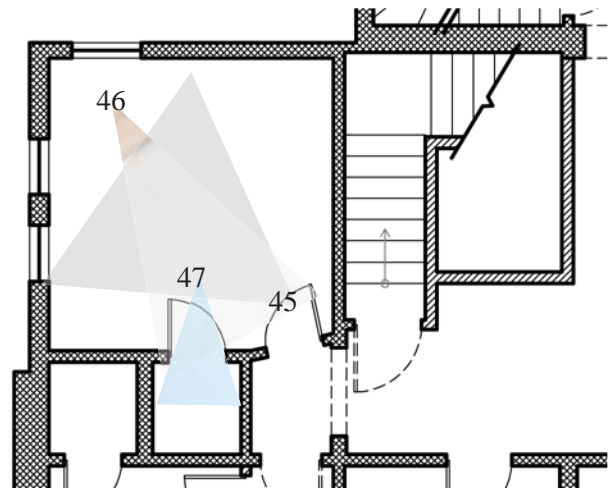

Ceiling- A similar paint has been added to this surface like the walls.

General Notes- The closet has been significantly altered from its original condition.



SOUTHWEST ROOM(S)

Southwest Room A -

Floor- The floor surface is carpet over original hardwood flooring. The carpet is in poor condition.

Walls- The original wood wainscoting is intact. Its condition is fair with some scratches, and the baseboard is heavily scuffed. Above the wainscoting the wall surface is painted over a paper-like material. Samples would have to be removed to determine the total layers of wall surface, and what the original wall surface would have been.

Ceiling- The ceiling has been modified with dropped ceiling that hides some mechanical ducts and forced air system. There is also a new florescent lighting system.

Doors & Windows- The room has one window located in the west wall of the room. The hardware and cords are not intact. The pulleys may have been removed, or simply covered over. The door to the room is not original but its hardware is intact and in good condition.

General Notes- This room has been significantly modified as evidenced by the mechanical controls and lighting located in south and east walls that were added after original construction.



48.



49.

Southwest Room A Closet -

Floor- The floor surface is carpet over original hardwood flooring. The carpet is in poor condition.

Walls- The original wood baseboard is heavily scuffed. The wall surface is painted over a paper-like material. Samples would have to be removed to determine the total layers of wall surface, and what the original wall surface would have been.

Ceiling- A fire-suppression system has been added to this room and has a pipe and sprinkler head that are visible just below the ceiling surface.

Doors & Windows- There is a transom window located above the closet door. The door is original but the door hardware is not intact.

General Notes- The closet has mostly maintained its original condition.



50.



51.

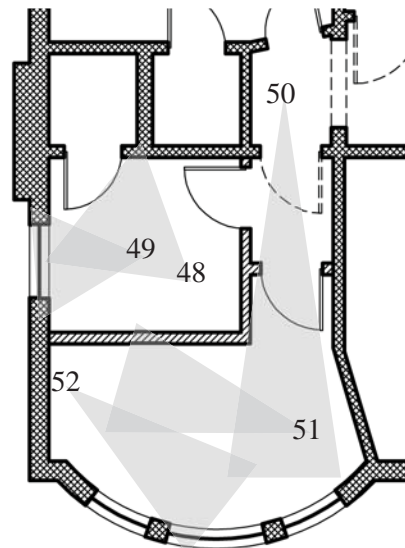



52.

Southwest Room B -

Floor- The floor surface is carpet over original hardwood flooring. The carpet is in poor condition.

Walls- The original wood baseboard is heavily scuffed. Electrical plugs and wire molding have been added. The wall surface is painted over a paper-like material. Samples would have to be removed to determine the total layers of wall surface, and what the original wall surface would have been.

Ceiling- The surface is the original with no modifications.

Doors & Windows- The room has two windows located in a curved bay in the south wall of the room. The windows are curved to match the curvature of the bay. The hardware and cords are not intact. The pulleys have been removed, or simply covered over. All the doors and door hardware are intact and in good condition.

General notes- The original room is divided into two rooms with a vestibule type space coming from the hallway into this room. The new wall separating the two rooms is a recent wood frame construction with gypsum wallboard and wood baseboard.



53.



SOUTH MIDDLE ROOM

Floor- The floor surface is original hardwood flooring. The floor is in poor condition with many scratches throughout the room.

Walls- The original wood baseboard is heavily scuffed. The wall surface is painted over a paper-like material. Samples would have to be removed to determine the total layers of wall surface, and what the original wall surface would have been.

Ceiling- The surface is the original with no modifications.

Doors & Windows- The room has two windows located in the south wall of the room. The hardware and cords appear to be intact. All the doors and door hardware are intact but not in good condition.

General notes- This room had a small lavatory in the southeast corner. The fixtures have been removed and the room is not functioning as originally built.

South Central Bedroom Closet -

Floor- The floor surface is vinyl over original hardwood flooring. The floor is in poor condition.

Walls- The original wood baseboard is heavily scuffed. The wall surface is painted over a paper-like material. Samples would have to be removed to determine the total layers of wall surface, and what the original wall surface would have been.

Ceiling- The surface is the original with no modifications.



54.

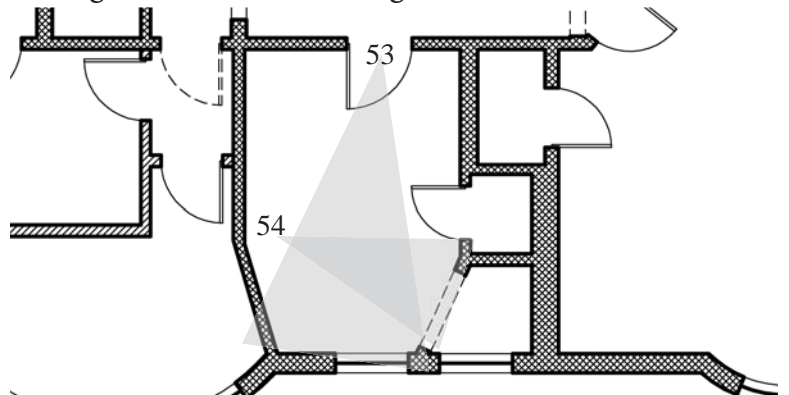



55.



56.



57.



SOUTHEAST ROOM

Floor – The wood flooring is original and has some scratches.

Ceiling – A fire protection system has been added to this room and visible pipes and sprinkler heads hang just below the ceiling surface. A ceiling fan hangs in place of an original light fixture.

Doors and windows – The room has three windows located in a curved bay in the southeast corner of the room. The windows are curved to match the curvature of the bay. Two windows are presently fixed and missing their original hardware. Only the south window is operable and has its original hardware. The upper window systems have been replaced with flat glass rather than curved. Narrow shelves that are not original have been placed between the upper and lower window systems. All the doors and door hardware are intact and in good condition. Each door frame has an operable transom window with original hardware but the glass in the transom above the access door into this space is missing.



58.



59.



60.

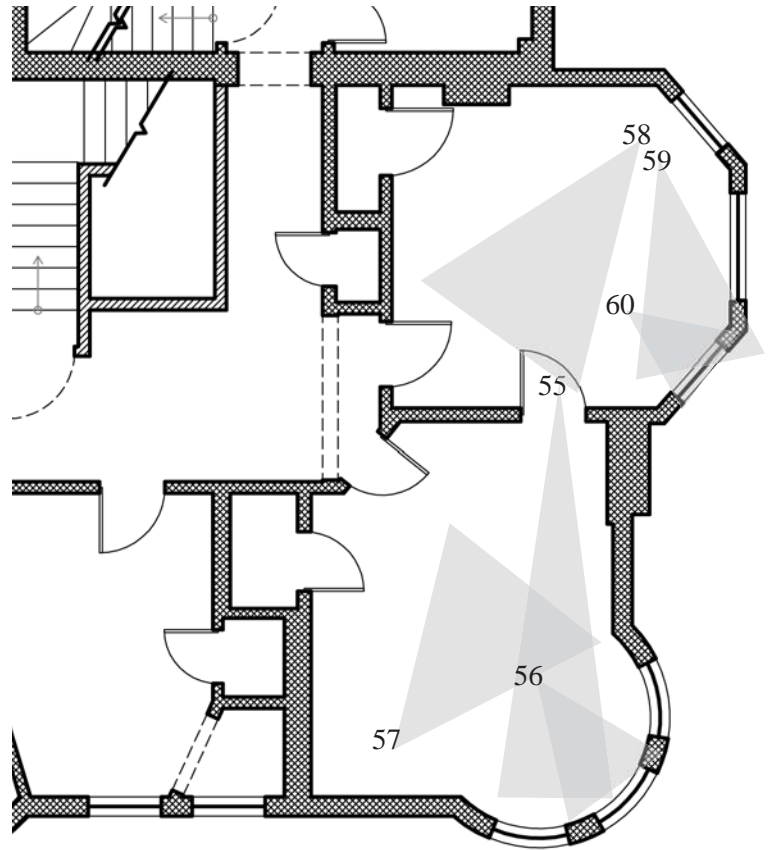

EAST ROOM

Floor – The wood flooring is original and has some scratches (image 60).

Walls – The paint is bubbling where the wall meets the ceiling. The source of the bubbling will need to be explored.

Doors and windows – The room has three windows located on the east wall. Two of the windows have a bottom sash that is operable. The frame of the third window on the right side has been modified to allow maintenance access to the porch roof (image 60). The upper sash appears to be a fixed transom.



61.



BATHROOM

Floor – The floor treatment currently is linoleum but the original was likely wood, in keeping with the character of the other spaces on this level. The linoleum would have to be removed to see what is underneath.

Walls – Wall partitions were constructed more recently with

Ceiling – The ceiling is constructed with gypsum wallboard and has been lowered to accommodate recessed lighting.

Doors and windows – The window to the right does not close completely.

General notes – This room was renovated to accommodate this bathroom. Removal of the bathroom elements may reveal the original layout and purpose of this space.



62.

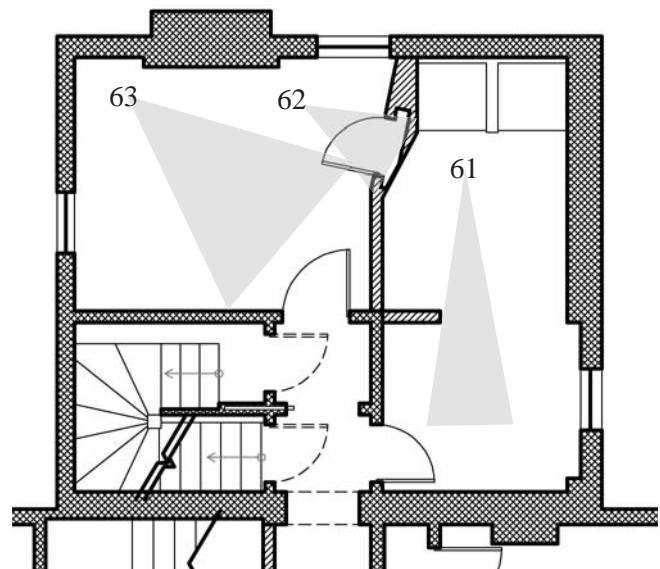



63.



NORTH ROOM

Floor – The wood flooring is original and has some scratches.

Doors and windows – The closet on the east wall has been removed to accommodate the bathroom showers and that rough-in is visible from what remains of the closet. There is a small 2' x 3' window on the west wall with six lights over one that appears to be original. The door into the space is hollow core door and not original to the space.

General note – This room is separated from the main part of the house by a pocket door and is accessed by the rear staircase. Its original purpose was likely servant quarters.



64.



HALL/LANDING

Floor – The wood flooring is original and has some scratches. Piping for the fire system has been added and punches through the floor near the north room.

Walls – The original wood wainscoting is intact. In this room, the wainscoting is about 32" high. Its condition is fair with some scratches, and the baseboard is heavily scuffed. Above the wainscoting the wall surface is painted over a paper-like material. Samples would have to be removed to determine the total layers of wall surface, and what the original wall surface would have been. The load bearing wall near the hall's pocket door has cracked plaster. The walls around the grand stair are made of gypsum wallboard and replaced an original railing system. Looking through a hole in this wall, an original skylight is visible above the staircase (image 65).



65.



66.

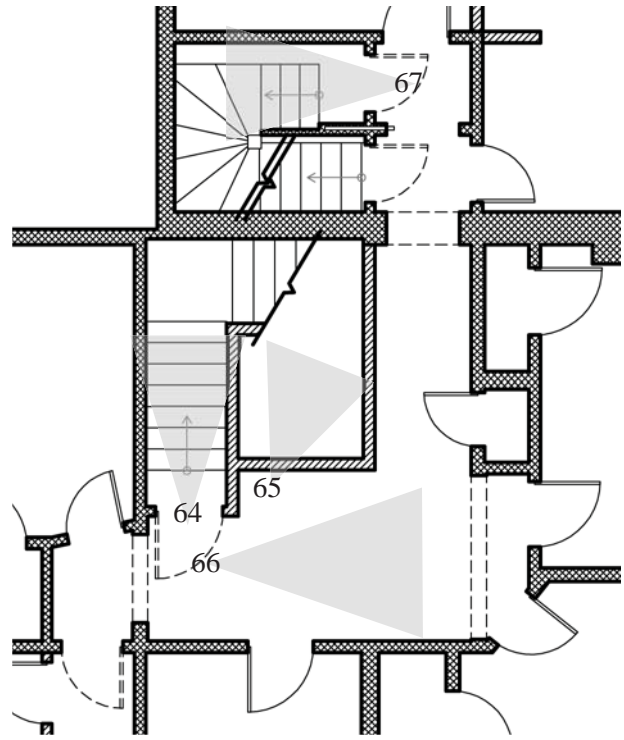

Ceiling- A fire-suppression system has been added to the space and has pipes and sprinkler heads that are visible just below the ceiling surface.

Doors and windows – A door frame has been added to the stairway leading up to the attic. The door that sat in this frame no longer exists. The pocket door is missing its original hardware. A new door has been installed at the top of the grand stairs.

Stairs to Attic – The wood flooring is original and has some scratches. A post is missing but is lying on the floor to the side of the stairs.

General notes- This room has been significantly changed from its original condition, especially around the stairway.



67.

EXISTING CONDITIONS FLOOR PLAN:

Scale 1" = 200'

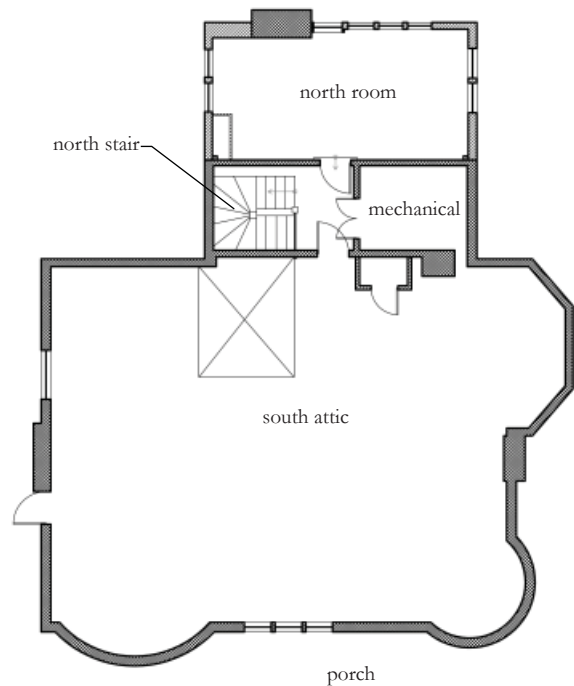

ORIGINAL WALLS



CHANGED WALLS

The following section describes the existing condition of the attic level. A summary of second level conditions includes:

- The attic space appears to have originally been one large space.
- The north room appears to be a later addition to the space.
- The floor surface is carpet, the original flooring surface still needs to be determined through a more thorough investigation.
- Additional supports appear to have been added to cister the roof structure and should be evaluated by a qualified professional.



68.



SOUTH ATTIC

Floor – There is a green carpet sitting on top of plywood. This in turn appears to be on top of a layer of linoleum. Under all of this remains the original wood plank flooring. There are some instances where the columns supporting the roof are sitting on a short plank. This is not the original condition as these pieces are sitting on top of the new flooring. It may have existed in this fashion on the original floor.



69.

Skylight Screen – The decorative iron screening above the grand staircase (image 68) has been covered by a makeshift stage for several decades. It is missing several of its opaque glass or fiberglass panels. The ironwork is in good condition. A banister (image 69) against the wall still exists and speaks to the existence of a railing around the skylight.



70.

Walls – The existing wall is the original brickwork (image 71). The white wooden projections extend to the exterior as the eaves of the roof. Some project into the room to meet supporting rafters. It is unclear if the other beams projected further into the room originally or if they have always been cut flush with the brick wall. There are many loose bricks and some are missing. The mortar is also coming loose in several areas throughout the wall.



71.

Another section of the brick wall on the east side is patched up with wood. There is a corresponding element on the exterior of the house that may have served a function at one time from this area. That function is unclear.

On the south wall, much of the brick is covered up with some damaged painted cardboard. There are also small partitions in this same area that are composed of gypsum wallboard and framing.

Ceiling – The ceiling is made from gypsum wallboard and painted with a popcorn texture. The electrical wiring, fire protection, and HVAC have been mounted directly to the ceiling. The closet to the right of the door holds the HVAC unit that supplies the attic spaces. There is also

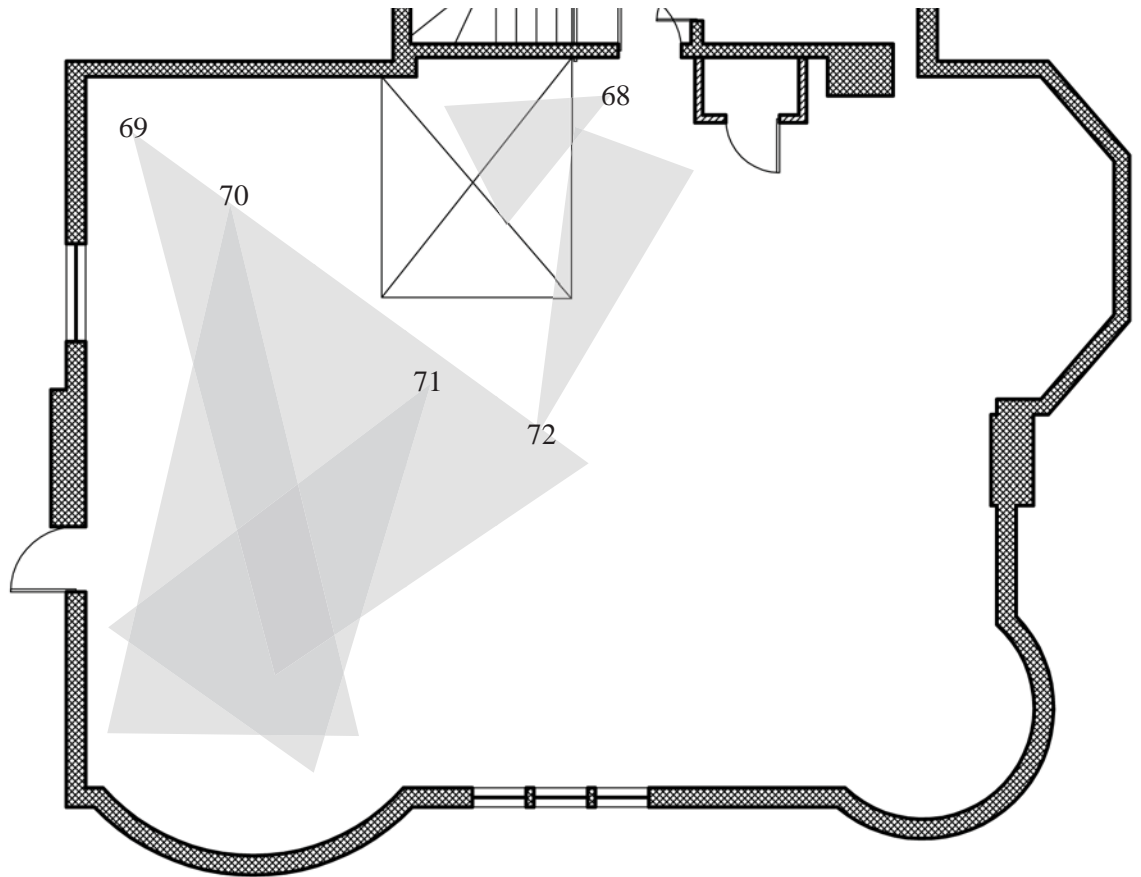

duct work from a swamp cooler on the east side of the space that has been blocked and is no longer in use. The swamp cooler unit is still attached to the roof.

Wired glass was introduced in the 1890's, around the time the building was constructed, so the skylight in the ceiling could be original (image 69). There are several cracks in the glass that will need attention.

Doors & Windows – The main entry door into this space is made of a metal and is not original to the home (image 72). Its paint is worn away around the push side of the door. The emergency exit door was a later addition when the building use changed. There is a fire escape that was added to the other side of this door.

There are only two sets of windows in the space. The three windows on the south side are aluminum, while the window on the west side has an older appearance and is partially boarded up. This window does not fit the opening and the gap below it is filled with a type of foam to act as an insulator.



72.



73.



74.



75.



NORTH ATTIC

Floor – The floor is stepped lower than the rest of the attic floor by one step. The floor treatment uses the same carpet that has been used in the larger attic space (image 75).

Walls - The walls are composed of both gypsum wallboard and a wood paneling. The west and left half of the north wall are gypsum wallboard, while the rest is wood paneling. The north gypsum wallboard section steps into the room a couple inches, accommodating the extended exterior north chimney. There is a small closet on the west side of the space that was added later and made with plywood. On the east side of the door is a medicine cabinet that was also added later. It is no longer securely fastened to the wall. Part of the paneling is missing near the door frame, exposing the framing behind it. Its overall condition is fair with some scratches. There are other openings around that cabinet for duct work.

Ceiling – The ceiling is composed of the same wood paneling as the walls. It is in good condition

Doors & Windows – The door is a light colored hollow core door and requires an immediate step down into the space.

There are two aluminum sliding windows on the west side of the room. The left window has a plastic covering on the exterior while the right window has a plastic covering taped to the interior. The left window had plastic taped to the interior as evidenced by the tape remaining on the sill. The paint has peeled away from the areas that had been taped.

The north wall has four mismatched windows. The first window from the left is a double window system with an exterior awning window and an aluminum sliding glass window on the interior. The second window appears to be fixed glass. The remaining two windows are both awning windows. All the window frames have areas of chipped or worn paint and the glass for all four windows is in good condition.

There are two windows on the east wall, both awning style. The left window is covered in plastic and tape remains from the right window where plastic once hung.

General Comments – This space is an addition to the original house and its design does not follow the original character of the building.



76.

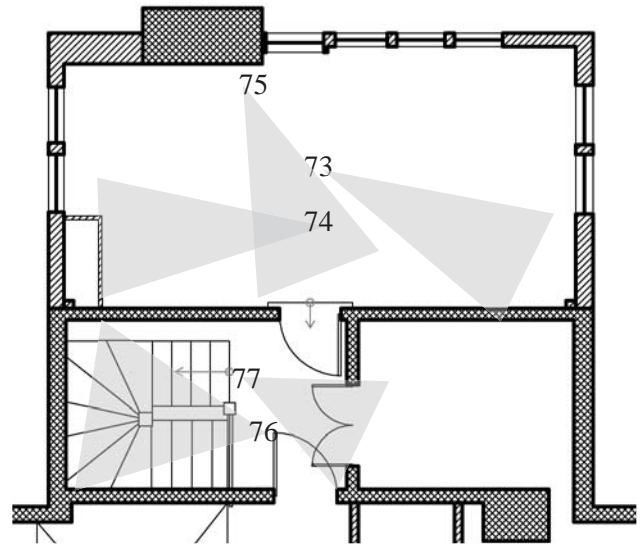

ATTIC MECHANICAL

General Comments – This room holds a cistern and other mechanical components. It is accessed through a decorative cabinet with glass doors. The cabinet style and detailing matches the character of the rest of the mansion but seems out of place. It may have originally been located on one of the lower floors before the additions were constructed. Its condition is fair with some scratches throughout. The latch was added later to keep the doors of the unveled cabinet closed.



77.

PART III

PHYSICAL DESCRIPTION

SECTION C

CARRIAGE HOUSE





78.

In 1933 a survey was completed on the carriage house and submitted for record in the Library of Congress. The completed HABS report and drawings can be found online at <http://hdl.loc.gov/loc.pnp/hhh.ut0042>

EXTERIOR

The roof appears to be an asphalt shingle applied directly over the original cedar shingles. The roof surface is seriously deteriorated and is no longer water tight. Large holes in the roof are allowing moisture and animals to enter the building.

The exterior brick is deteriorating, beginning with mortar failure, which is allowing water to penetrate into the wall.

The watetable around the foundation of the building is also showing signs of weather damage., especially where site concrete sits adjacent to the exterior walls.



79.

MAIN LEVEL

The main level floor plan is still intact, although the condition of the plaster walls themselves is poor. The ceiling consists of exposed joists and the underside of the upstairs floor boards. The ceiling structure appears to be sound.

The stairs leading up to the second level are in a state of decay. Several treads have already broken in.



80.

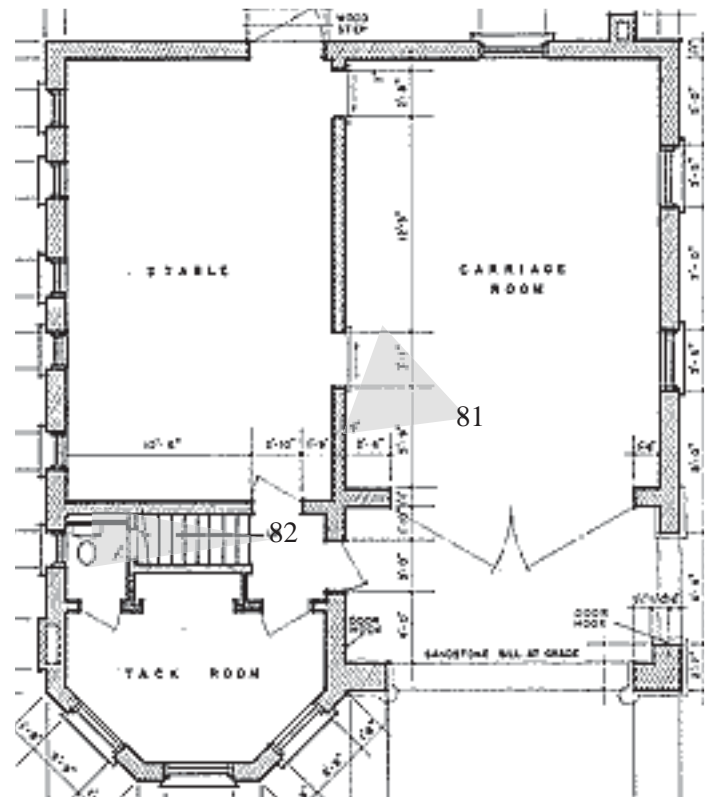

81.



82.

ATTIC LEVEL

The attic level is seriously deteriorated. The plaster in the two south loft rooms is nearly saturated with moisture and falling off the lath surface.

The holes in the roof are apparent. Birds are roosting in the roof rafters of the main loft area.

The roof structure itself appears to be sagging and should be evaluated by a structural engineer.



83.

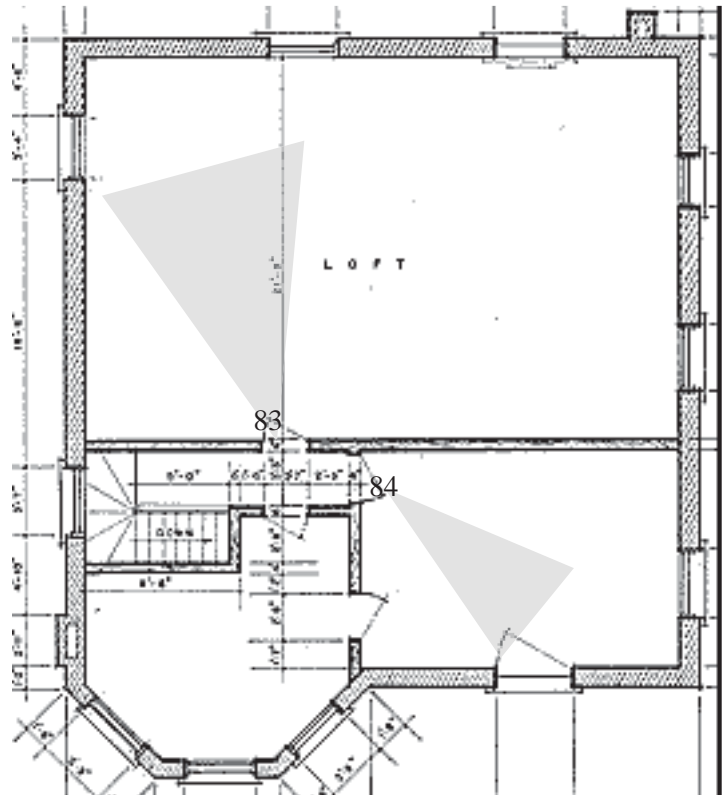

84.

PART IV

RECOMENDATIONS



HISTORIC PRESERVATION OBJECTIVES

Recommendations are based on the general group consensus to restore the building to its original 1893 design and condition since its future use is unknown at this time. Exceptions to a complete restoration include elements that must adhere to current code and regulations like plumbing, electrical and ADA compliance.

GENERAL RECOMMENDATIONS

Site

The site design should be adapted to accommodate the new use of the structure, while restoring as much of the original landscape to a 1893 period of significance. It will be especially important to examine the circulation issues related to the new use of the building – specifically parking, accessibility, and the long term maintenance and sustainability of the site and landscape. Some general hardscape recommendations include:

- If possible provide off site parking on an adjacent parcel.
- Re-design the existing parking to provide vehicular access for drop-off, delivery, and handicap parking.
- Provide bicycle racks to encourage cyclists to visit the facility.
- Reduce the general amount of on-site paving to minimize visual impact on existing structures
- Avoid paving directly against building foundations, remove existing paving that sits against building surfaces.
- New paving should be permeable to allow for water infiltration, and be materially compatible with the types and methods of paving available in the late 1800's. Paving options include, historic concrete, macadam asphalt, stone pavers, and compacted decomposed granite or crushed stone.

Existing/replacement strategies – Original plant material should be preserved wherever possible, or replaced with specimens that match the original plantings. Seasonal observations/site archeology could determine the original locations of planting beds, which should then be restored with period plantings. The recent evergreen plantings should be removed, as they are planted too close to the building and are blocking views and will eventual cause damage to the building. Also, vines attached to the structure should be removed. Depending on the proposed use of the building, the city may also want to remove the water feature that was added in the back yard, as it may be a maintenance issue, and restore the back portion of the property to a designated period of significance. A working garden could be created in the location of the original kitchen garden and operated as a demonstration garden or community garden to illustrate small-scale agriculture in promotion of sustainability.

Sustainable site strategies – Strategies include amending the soils under the recommendations of a Landscape Architect and Soil Scientist to build healthy soils that retain moisture, provide nutrients to plant material, and allow for deep rooting of plant material. Minimal irrigation intervention should be required, and would be limited to establishing lawn areas, and drip irrigation for new shrub beds. The planting design should focus on providing 100% plant coverage and maximum canopy to shade the

ground surfaces, providing cooling evapotranspiration, and to create a healthy living plant community that requires minimal maintenance. Plant species should be in keeping with the original plantings used on the site or with plant varieties that were widely available during the Victorian period. Plants selected should also be drought-tolerant and native Utah or adapted plant material that has proven successful under Salt Lake City's climactic and soil conditions.

Main Building Exterior

The overall exterior of the building is in good condition. There are areas of the east façade where birds have nested. These areas need to be cleaned to remove the bird droppings and nesting materials. Chicken wire has also been added to an area on the east façade and needs to be removed.

Foundation – The foundation is in good condition and has already undergone some repair. Some of the external vents and also the grates underneath the main porch need to be securely fastened in place. The decorative concrete details of the front porch are showing signs of weathering and cracking. This problem requires further attention by a professional to assess a possible solution.

Exterior masonry – Most of the exterior masonry has become stained and requires attention. A professional mason should assess whether it is viable to clean the brick. Special attention should be drawn to the top of the chimneys that have become blackened by soot and also an area on the east wall where the brick has become stained black due to a failing rain gutter downspout.

Facia – The stamped metal facia just below the roof line shows signs of rusting and has all been painted. It should be investigated whether or not it is possible to remove the paint and provide a coating of weatherproofing to the restored facia.

Exterior siding – Some of the shingle siding requires paint.

Roofing – The roof appears to be in good condition along with the exterior flashing.

Carriage House Exterior

General stabilization issues – There are many broken and missing windows, the roof is in disrepair, and there is a pigeon problem. There has been an attempt to keep birds out through the installation of chicken wire all over the roof but that is failing. There is a large amount of bird feces that will need to be cleaned. The structure appears to be sound other than the roof. Overall, this building is in very poor condition and requires immediate attention to avoid further deterioration.

Foundation – The foundation appears to be in fair condition. Stabilize and repair the areas of crumbling sandstone. Repair missing mortar and damaged bricks.

Exterior masonry – The bricks are in good condition overall. There are some bricks where the face has broken off. Repair these damaged bricks to avoid further decay. Clean and repair the sandstone window-sills. Many of them are weather worn and in poor condition. There are some instances of missing mortar that need to be replaced. The larger chimney appears to be in good condition but should be more closely examined to ensure its state. The smaller chimney on the northeast corner will need to be stabilized and mortar replaced.

Wood – All the doors have damage. Repair the scratches on the front door. Repair the area of the

overhead door in the front where the plywood is covering. The rear door wood veneer is peeling away and will need to be replaced. Repair all doors as necessary and paint.

The decorative wood molding near the roof appears to be in fair condition but could use a closer inspection. Replace areas that are missing or rotten. Repair and restore all other areas.

Windows – There are many missing and broken windows throughout the building. Replace broken lites and missing windows with windows that maintain the character of the building.

Roofing – The roof is in poor condition and needs immediate attention. There is water damage, rot, and general decay. Replace missing eaves with same style as existing. Repair remaining eaves. Inspect the overall roof structure including the cupola and gables and repair or replace according to structural needs. Replace areas of rot and secure from further water infiltration. Replace decaying wood shingles with new wood shingles. Inspect wood shingle cladding on the cupola and gables. Repair and replace as necessary and then paint. Repair the gutter and roof drainage system. The drainpipe on the west side has rusted away and will need to be replaced.

Main Building Interior

Depending on the future use of the facility, we recommend the removal of all additions and restoration of these areas to their original functions, uses and character.

Basement – This space should be used for storage only and should not be accessible to the public.

Floors – Restore all floor materials to their original character. In most cases, this will require the removal of carpet or linoleum and restoration of the hardwood flooring that is typical throughout the home. Some rooms have tile flooring. This should be replaced or restored to meet the surface finish that would have existed during this period.

Baseboards & wainscoting – In most rooms, there is a hardwood base that should be cleaned and restored to its original finish. Some rooms contain original wood wainscoting that is intact. This surface should also be cleaned and refinished to remove the scratches and scuff marks that are existing.

Walls – Take samples of the various layers of wall treatments. Refinish wall surfaces to be consistent with the use of the rooms.

Ceilings – Recess the fire-suppression system in the ceiling if possible to preserve the character of the original spaces.

Doors – In most cases, doors are intact. In all cases, the original door hardware should be restored so that they are intact and operable.

Windows – Most of the windows are in good condition and simply need to be cleaned. Some windows are cracked and need to be replaced. Others are not historically accurate and should be replaced to maintain the buildings original character. Missing hardware should be restored. Refer to the physical description notes to know which windows are damaged or missing components.

REQUIREMENTS FOR WORK

General code compliance issues (ADA) – Since the building will likely be a public one, it is important that accessibility issues are considered. An elevator should be installed. One possibility without adding square footage is to install the elevator on the northeast side near the first floor addition and second floor bathroom. Another option is to add a new elevator shaft on a secondary façade like the north elevation. Accessible parking stalls and ramps should be included to make the building easily available.

Electrical – Inspect electrical system to ensure that it will safely respond to future loads. See Appendix C for more information.

Heating, cooling, and ventilation – Original elements that contributed to the building’s ability to passively heat and cool should be restored. See Appendix C for more information.

Plumbing– Assess plumbing infrastructure for leaks and make sure pipes are code compliant. See Appendix C for more information.

Energy conservation and sustainability – Considerations for environmental impacts on the restoration of this structure should be ever present. See Appendix C for more information.

ALTERNATIVES FOR TREATMENT

The recommendation that would have the largest impact on the way this building stands currently is that of removing the later additions. These additions could remain intact not only to save money and space in the landfill, but to fulfill the new purpose of the building. The fact that they are on a secondary façade makes their existence acceptable.

The site could remain as it is presently but the removal of elements that may cause damage to the building should be addressed.

In conclusion, this building is in great condition and maintains many of its original components. It is a great asset and a beautiful piece of our Salt Lake City heritage. Through the recommendations given, Fisher Mansion has the potential be returned to its original character.



BIBLIOGRAPHY

Bash, J. (1993, October). *Albert Fisher Mansion observes its Centennial and Modern Purpose as Shelter for Homeless Men*. News Editor, p. 29.

Goodman, J. (1991, December 1). *West-side Mansion Nears Centennial*. The Salt Lake Tribune, p. E 13.

Hale, K. & Straube, M. (2008, January). *Albert Fisher Mansion- Built 1893*. A Salt Lake Solutions Project, p. 1-3.

Jensen, D. (2008, January). *Becker wants historic Fisher mansion, a 'hidden jewel,' open to public*. The Salt Lake Tribune, p. 1.

Page, J. (2008, February 9). *A Toast to historic S.L. Victorian*. Deseret Morning News, p. B.01.



MAIN LEVEL

Scale 1" = 100'

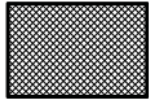

ORIGINAL WALLS

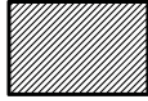

CHANGED WALLS

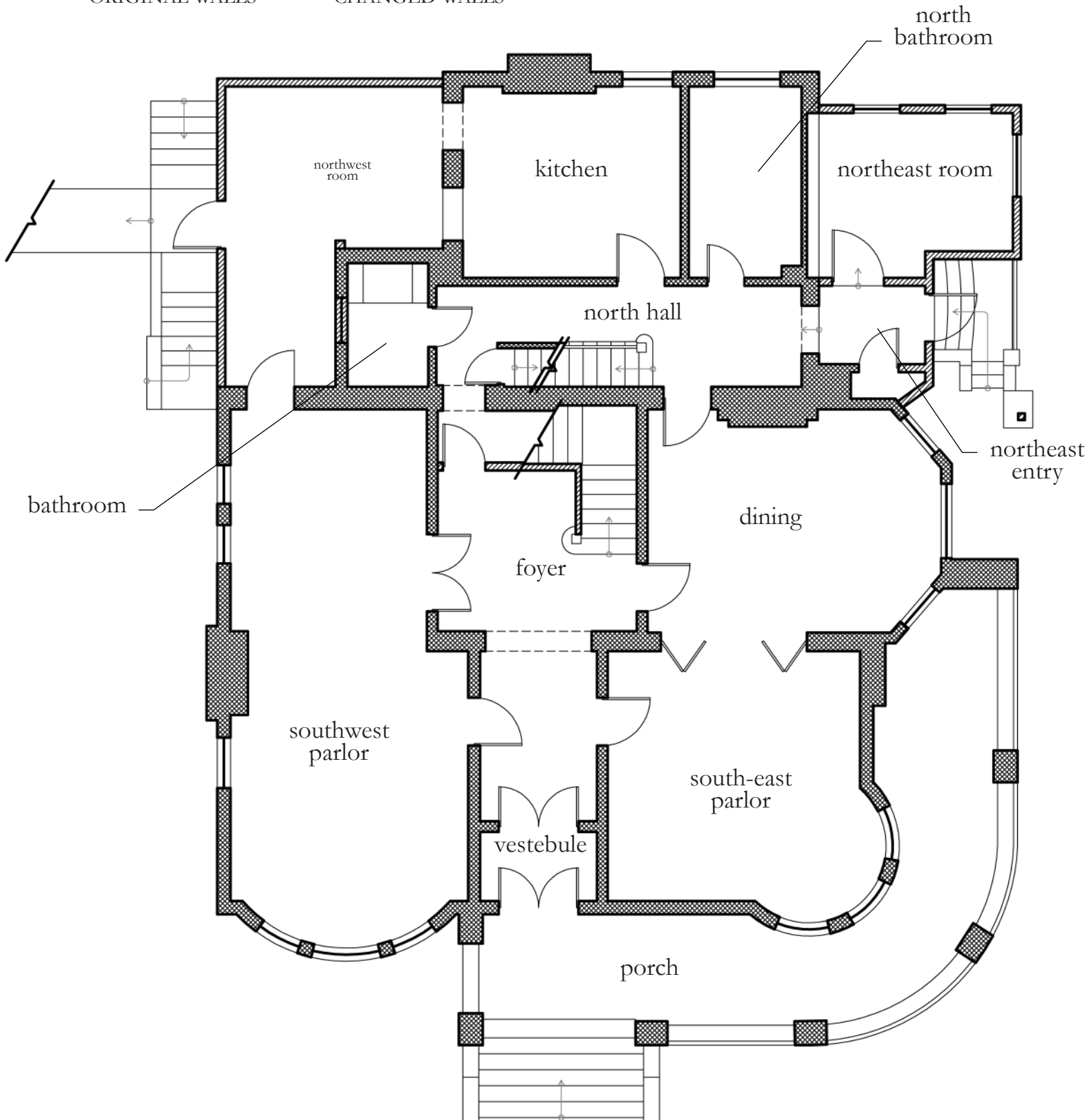

SECOND LEVEL

Scale 1" = 100'



ORIGINAL WALLS

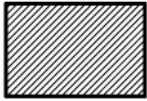

CHANGED WALLS

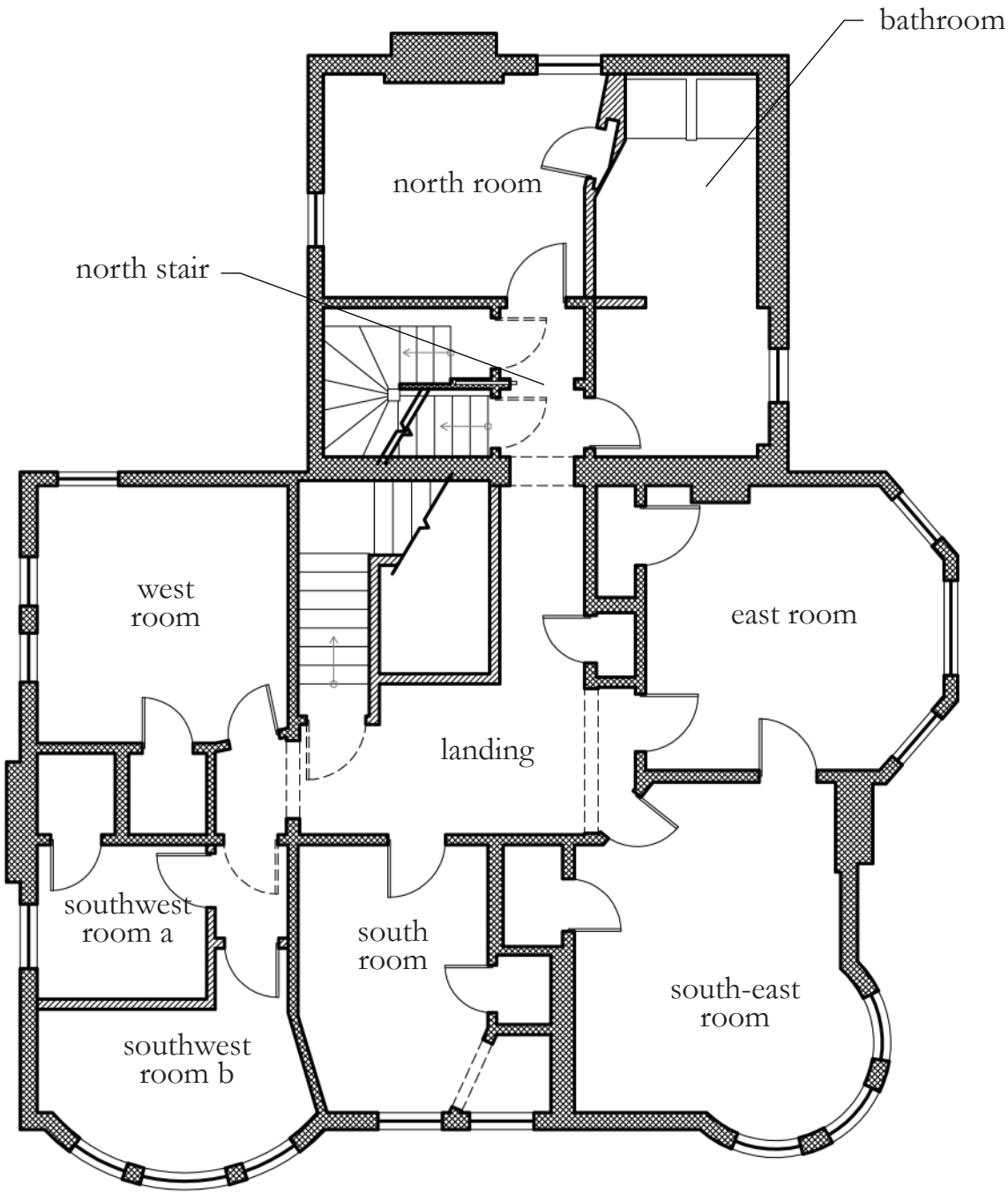

ATTIC LEVEL

Scale 1" = 100'

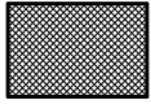

ORIGINAL WALLS



CHANGED WALLS

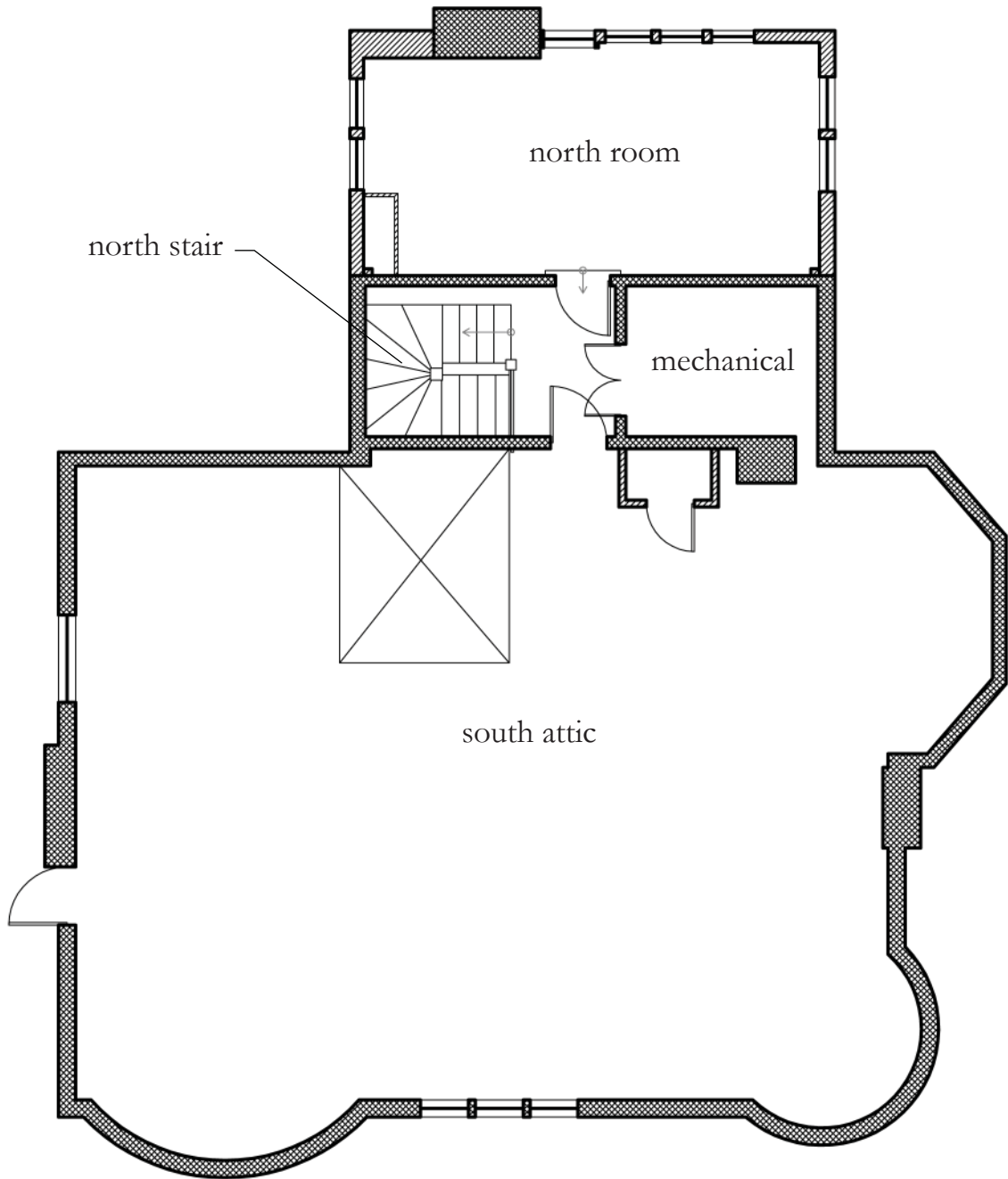

CARRIAGE HOUSE - HABS DRAWINGS

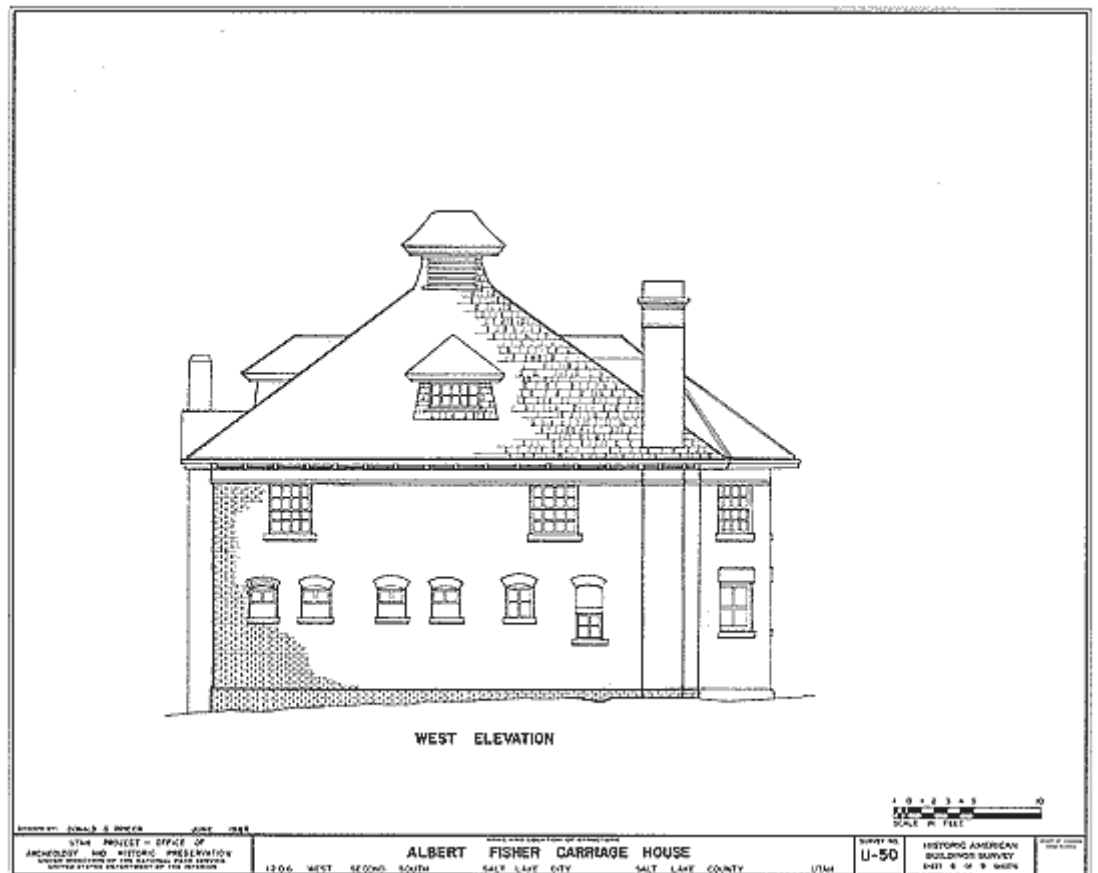
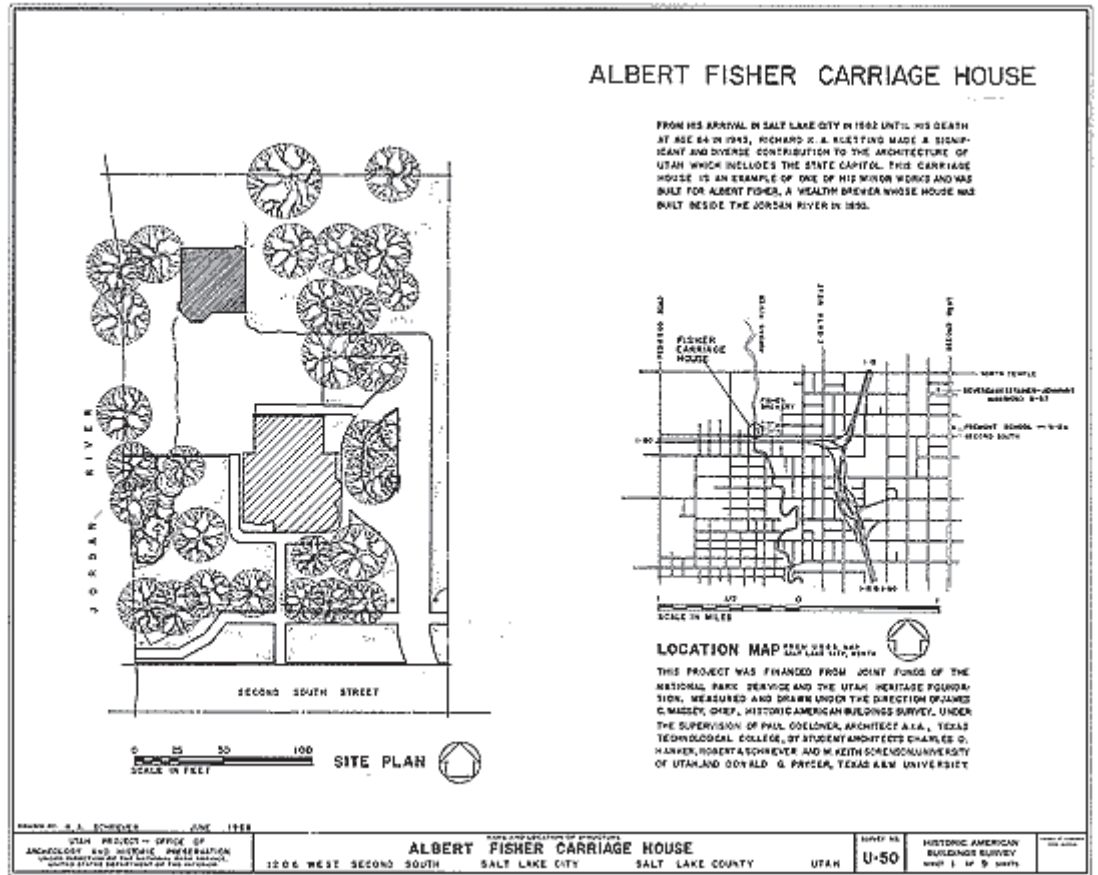

CARRIAGE HOUSE - HABS DRAWINGS

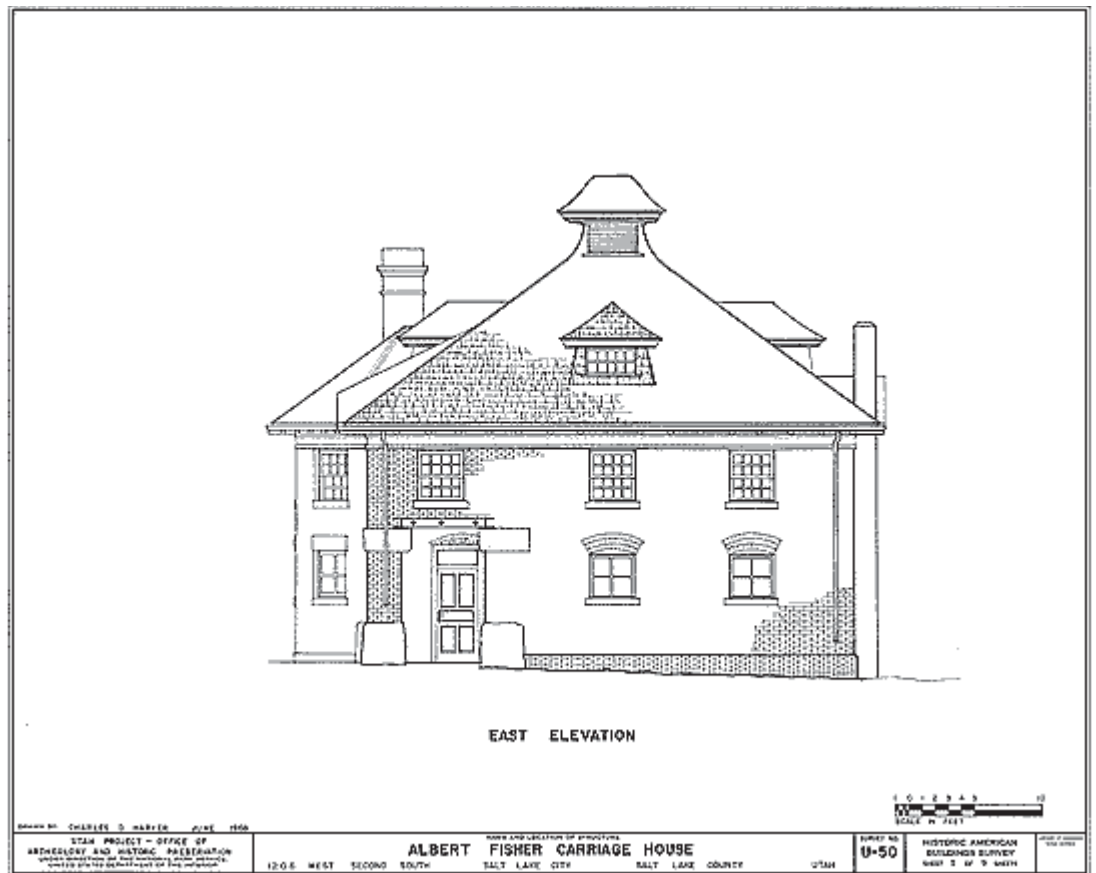

CARRIAGE HOUSE - HABS DRAWINGS

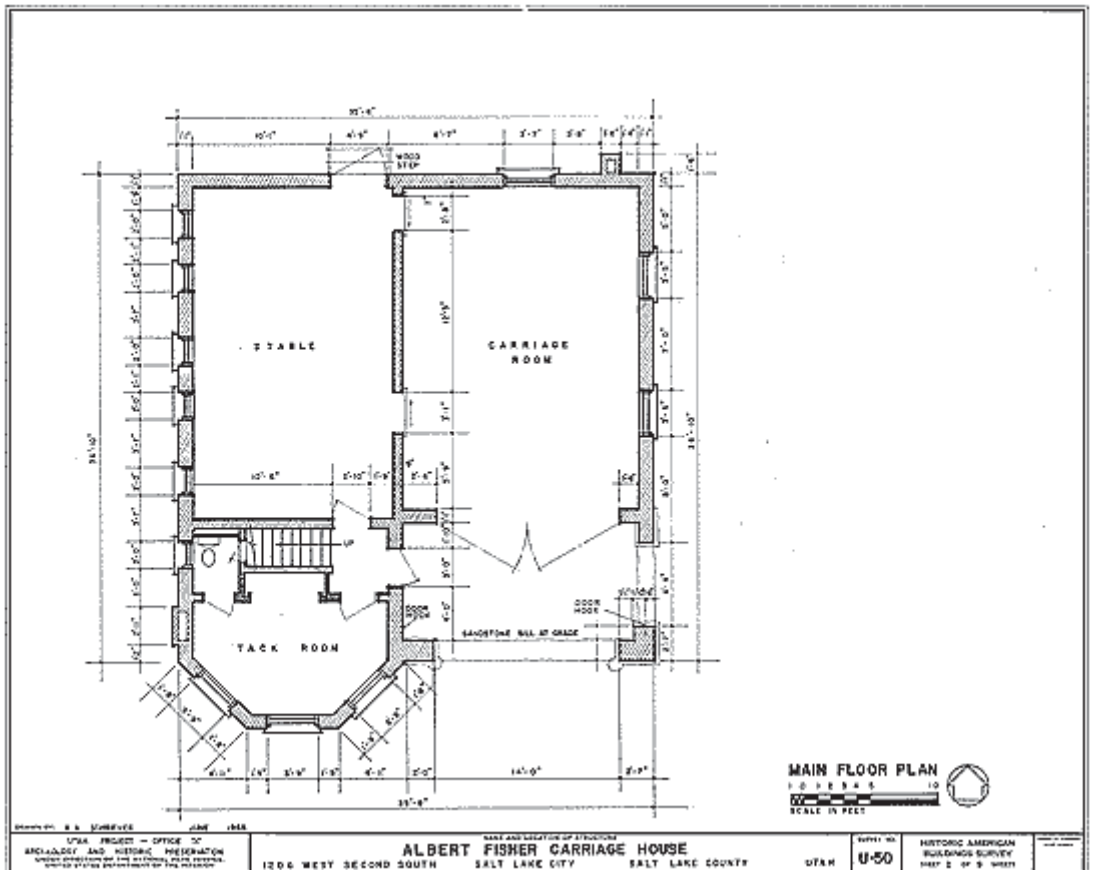
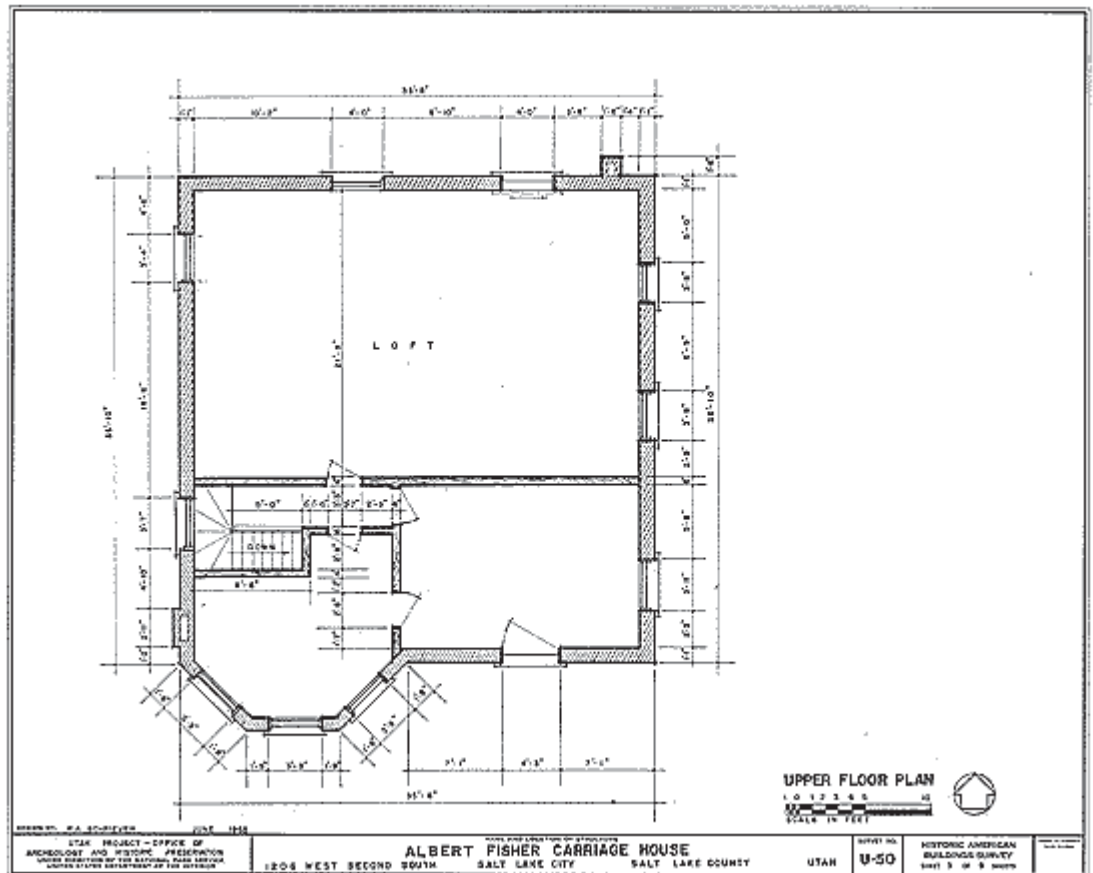

APPENDIX C

Sustainability and Energy Conservation/ Efficiency Considerations

Supplemental Consultant's Report by Robert A. Young



Any alteration to the exterior of the building that affects the exterior visual appearance will need to be reviewed by the Salt Lake City Historic Landmarks Commission (SLCHLC). This would primarily involve the introduction of replacement windows, roof mounted photovoltaic panels and solar hot water panels, and any roof mounted HVAC equipment systems that are visible from a public way. Likewise any additions to the building must conform to the SLCHLC design guidelines. Placement of panels and mechanical equipment on the ground adjoining the building may be possible after consultation with the SLCHLC so long as they do not diminish the visual appearance of the building or grounds.

Two Overarching Aspects

Often overlooked in many adaptive use projects are the concepts of embodied energy and the impact that reusing/recycling buildings and their components can have on advancing the goals of sustainable design. In this light, the immediate urge to completely replace a building component should be tempered by the recognition that with each component that is simply sent to a landfill and is not recycled, the energy that it took create that element is permanently wasted. Similarly, every component that is thrown away imparts new pressures on landfills and creates the need to extract new raw materials and use energy to fabricate its replacement.

While not all building components can be immediately sequestered into a recycling stream, the decision to demolition them and replace them with a new element should be considered carefully. When the true recognition of embodied energy and the reduction of new extraction and demolition waste streams are understood, then the true measure of how sustainable the strategies of preservation and adaptive use will become more apparent and subsequently a larger part of the sustainability movement.

Character defining passive thermal and daylighting features

Constructed in a period before modern heating, ventilating, and air-conditioning systems had been introduced, the Fisher Mansion is typical of buildings that were designed in relation to the available passive non-mechanical systems of the era. Site orientation, building materials, building massing, and attention to solar access for passive solar heating and daylighting were more common and better understood to be a basic part of the thermal and luminous environmental control systems of a building.

The Fisher Mansion is comprised of primarily brick facades with stone foundations, sills, lintels, and other ornamental stone features. There is a limited amount of wood shingle-clad, stick-framed wall enclosing the north portion of the third floor. The roof is comprised of shingles attached to sheathing nailed to a wood framing system. The vertical massing of this house is typical of home of this type and originally featured a central skylight atrium that has subsequently been enclosed with gypsum wallboard and stick framing. The two-story Carriage House located to the northwest of the Fisher Mansion is similarly constructed of brick with a shingled roof. As was common for outbuildings of the period, there was no insulation installed during its original construction.

The site has several fully mature deciduous trees whose leaves provide a natural solar shade during the summer months. During the winter months, the bare deciduous trees admit significant quantities of solar radiation which aids in passive solar gain of the building. The site adjoins the Jordan River which flows along the western boundary of the property and may provide some cooling relief due to the effects of evaporative cooling in the area immediately adjoining the river. There is little undergrowth in the landscaping to interfere with beneficially cooling summer breezes but conversely the landscaping does little to deflect winter winds. Although the predominant winter wind direction in Salt Lake City is from the SSE, the Carriage House does act as a wind deflector when colder winter winds come from the

northwest.

Like other large residential buildings of this era, the Fisher Mansion originally took advantage of porches to provide shelter from the sun and the rain. The main porch along the south and east elevations remains in place while the secondary porches at the northeast and northwest corners of the mansion have been expanded and/or enclosed to create additional interior space. Large windows provided opportunities for passive solar gain in the winter and daylighting year-round. Operable transom windows above the exterior doors provided daylight and a means for passive ventilation when the doors themselves were closed. The vestibule at the main entrance provided an air lock to prevent winter winds from directly entering the first floor hall and adjoining rooms.

On the interior, key features include skylight stairwell (currently enclosed), high ceilings, light colored walls, glazing panels in doors, tall operable windows along the exterior walls, and transom windows above doors. The stairwell, which is conceptually an atrium that acts as a solar chimney, was a critical component of how the building was passively daylit and cooled. When the stairwell was originally constructed, the open, skylit stairwell allowed daylight to enter the central core of the building where it could brighten otherwise dark hallways and provide “borrowed” light through the glazing in the adjoining doors and the transom windows above them. The high ceilings allow summer heat to rise away from the habitable space of the occupied rooms. The existing light colored walls (presumably concealing darker Victorian era wall paper) enhance the reflection and penetration of the daylight into the interior spaces. The tall operable windows could be opened to admit fresh air when outside air temperatures were within the comfort range or simply to provide a comforting flow of moving air. Lastly the transom windows, provided a dual opportunity admitting daylight from the open stairwell skylight as well as an opportunity for cross ventilation when used in conjunction with the operable windows and the three story atrium created by the skylit stairwell. In the era of the construction of this house, prior to the invention of mechanical air conditioning systems, cross ventilation was a primary means of providing cooling comfort (or heat mitigation) by enhancing the passage of air through the occupied spaces. Nighttime cooling was achieved by leaving the lower window sash and transom windows open thereby allowing the air to flow through the rooms and enter the stairwell via the transom. The natural buoyancy of the warm air causes it to rise through the stairwell atrium and either flow into the attic or through a skylight in the roof.

Building Envelope

The stone foundation and brick exterior walls provide a thermal mass which mitigates the thermal variances due to the solar gain and acts as a thermal storage device. Unlike wood framed walls, masonry veneer walls, and modern metal curtain walls, heavy masonry walls act to more slowly absorb heat and then later release it when air and surface temperatures begin to fall. Although the common practice of using blown-in insulation or expandable insulating foam products is viable for modern twentieth century wall systems that feature a hollow wall cavity, masonry construction of the nineteenth century (and earlier) does not include a cavity to receive this type of insulation upgrade. One alternative that has been used to the severe detriment of interior finishes and living space has been to fur out a nominal cavity or by constructing an actual framed partition wall on the exposed interior wall surface, filling the cavity with insulation and enclosing the surface with gypsum wallboard or a modern plaster and lath system. The woodwork is then refit to match the change in dimensions of the casework and trim. This is not a viable solution for the Fisher Mansion interiors that are enclosed by the exterior masonry walls.

Another alternative is to blow in insulation or inject expandable insulating foams into wall and ceiling

cavities. Care should be taken to identify locations where the original knob and tube wiring could be compromised by either installation process. Blown in insulation comes in the form of cellulose (e.g., recycled newspaper) or shredded cloth (e.g., denim) that has been treated to make it insect proof and fire resistant. When using expandable foam insulation products, additional care is needed to select a foam product that does not introduce environmental contaminants into the building and is formulated for use in existing buildings. Many foam products are intended for new construction where the cavity space is filled with the expanding foam and then the excess is trimmed away before the interior gypsum wallboard is attached. Foams intended for existing construction do not expand as rapidly or as significantly and therefore reduce the possibility that the pressure created by the expanding foam will damage the existing plaster and lath already secured to the wall or ceiling. The following opportunities to increase the thermal insulation and decrease infiltration exist at the Fisher Mansion:

1. *Insulate wood-framed cavity walls and roof:* The wood framed roof of the Fisher Mansion and the walls of the room at the north end of the third floor are feasible candidates for insulation upgrades, if they have not already been upgraded. Further inspection by removing discreet portions of the wall and ceiling by an accredited professional will determine where these opportunities exist.
2. *Insulate ceiling at the foundation perimeter in basement:* There are a number of opportunities to investigate the feasibility of inserting insulation within the floor cavity along the perimeter of the building. Although the ceiling is enclosed in many of the rooms, it may be possible to demount the ceiling or to drill access holes in which to enable insulation to be blown or foam injected to reduce both thermal conductance and infiltration into the building along the top of the foundation walls.
3. *Insulate converted window openings in the basement:* There are several locations where original window openings have been converted to use as an air intake or discharge. The infill surrounding these ducts should be insulated and sealed to reduce thermal conduction and infiltration.
4. *Insulate/weather strip doors and other openings:* Several doors and other former window openings open directly to the outdoors or into the basement accessible crawlspace. These doors should be weather stripped and the openings should be filled or covered with an airtight insulated access panel.

Windows

The wood sash windows of the Fisher Mansion are a character-defining feature, especially the curved glass windows and beveled art glass windows located in the projecting bays and the tower as well as the art glass in some interior doors. While the single pane glass is less energy efficient than modern glazing such as double paned low-emittance windows, a major culprit in heat loss is through the infiltration of cold winter air (and to a lesser extent hot air in the summer) that occurs along the edges where the window sash and where the window frame and the building frame come together. There are several steps that can be taken to improve the efficiency of the windows:

1. *Caulking:* Infiltration due to lack of maintenance of caulking around windows is a common heat loss/heat gain problem in older houses. Verify the condition of caulking repair/replace as needed.

2. *Weather stripping*: Similarly, the absence or failure of weather stripping can allow infiltration to increase. Verify the condition and as repair/replace as needed. There are several strategies for inserting new weather stripping into existing windows that include installing V-shaped brass strips in the vertical spaces along the side of the sash. Similarly, it is possible to insert Velcro or other materials to form an infiltration barrier along the meeting rails of the upper and lower sash.
3. *Storm windows*: While exterior storm windows can be fabricated for the non-curved windows, the use of interior storm windows presents a less visually intrusive strategy that preserves the historic appearance of the exterior. These units can be fabricated to include interchangeable screen and glass inserts so that fresh air can be admitted during temperate months of the year. Aluminum exterior windows are not recommended since they will detract from the historic appearance of the building. Storm windows are not recommended for the curved glazing or the art glass windows in the tower and projecting bays.
4. *Double glazing*: In the flat glazing, it may be possible to replace the single pane glass with double pane inserts by removing the single pane glazing, routing an appropriate channel in the sash/muntin bars, and inserting a full double pane replacement. Consultation with a window restoration specialist can confirm the applicability of this strategy. Full replacement (both glass and sash) of the flat glazed windows may not be economically feasible since the cost to recover the demolition and the replacement cost of new windows have been shown to be less economical and less environmentally sustainable practices. Studies have shown that recaulking, weather stripping, and refitting the existing windows has a significantly shorter payback period than full replacement. However, should double glazing still be desired, the replacement windows can be simulated divided light or true divided light windows. In a simulated divided light window, one double-paned unit replaces all of the glazing in each separate sash. The exterior and interior portions of the glazing unit include false muntins as needed to replicate the original appearance of the window and provide appropriate shadow lines that give the window its historic character. The windows are custom made and the gap between the two panes of glass is concealed by a metal insert that aligns with the location of the muntin bars to provide the appearance of a continuous muntin bar through the window unit. In a true divided light window, each individual pane would be replaced with a double paned glazing unit that matches the pattern and size of the original window. Depending upon the number of false muntin bars, the simulated divided light window is typically less expensive than an assembly of true divided light windows. Reglazing the curved windows with double glazing will most likely be cost prohibitive since they will require a specific custom made window. For further information on this practice contact the Salt Lake City Historic Landmarks Commission or the Utah State Historic Preservation Office. Any replacement windows should match the original window opening size, the shadow profile of the muntin and sash, and the opening size of individual panes of the windows they replace. To install new windows of smaller size and infilling the space around them is not an acceptable practice under the Secretary of the Interior Standards (Standards) which form the basis for most reviewing agencies involved with the oversight of historic buildings. Similarly, complete replacement with vinyl windows with nominal shadow lines from muntins and sash and decreased window glazing open area is not acceptable. Lastly, replacement of glazing units with one single continuous sheet of double paned glazing that does not replicate the muntin profiles or omits them altogether is not in conformance with the Standards as well.

5. *Repair basement windows:* The basement windows should be reglazed and the weather stripping repaired or replaced. The broken or missing windows should be repaired or replaced. Specific attention should be given to those windows and crawlspace vents in the exposed foundation wall that lead directly for the exterior.

6. *Reopen the stairwell/atrium:* The central atrium skylight that forms the stairwell has been enclosed with a gypsum wallboard partition. The stairwell terminates at the third floor which was originally an unheated attic space. There is a second skylight located in the roof directly above the skylight that caps the stairwell. As explained above, this atrium originally acted as a primary passive mechanism for both lighting and ventilation. It is strongly recommended that efforts to reopen the stairwell should be pursued as it can provide a focal point for sustainable design efforts within the building. Beyond simply ensuring the visual privacy between floors, the construction of the existing enclosing partition was possibly driven by the need to retain heat on the lower floors in the winter. With this factor in mind, it may still be possible to reuse the stairwell as a daylighting and passive cooling element by enclosing the stairwell with a fire-rated glass enclosure system coupled with a thermostatically or digitally controlled louver or exhaust system located in the attic. Coordination of this design would involve the mechanical systems consultant, the Fire Marshall, and the intended occupants since this atrium would need to meet life safety requirements for fire and smoke control. A contemporary example of this can be seen at the Big-D Construction Company Headquarters in Salt Lake City.

Heating, Ventilating, and Air-Conditioning Systems

In its original construction, the Fisher Mansion was heated with a gravity powered warm-air furnace. There are no indications of any steam or hot-water radiators within the Fisher Mansion. Each room is served by a heating register located within the wall along the baseboard. The gravity return register is located in an alcove under the stairs at the first floor. The third floor was originally an attic space in which a mechanically driven warm air furnace has been added. Other heating sources came from the two fireplaces located on the first floor and are currently not in use. An assessment of the viability of reusing these fireplaces needs to be completed by a building inspector to determine their suitability for safe use.

Originally, cooling was based on the cross ventilation and the air movement effects generated by air moving through the interior spaces and the three-story stairwell/atrium. Currently there are several separate mechanical cooling systems in place at the Fisher Mansion. These include several evaporative coolers located on the roof and in windows adjoining the spaces they served. There is also one window air-conditioner serving a room that was created in the enclosed northeast porch. An air-conditioning condenser unit is located on the ground between the parking lot and the north façade. Visual inspection could not reveal what system this unit serves.

The original heating system is a centralized configuration with the furnace located in the basement. The centralized nature of this warm air system enabled a variety of filtration and humidification aspects not found in buildings heated by steam or hot-water radiation alone. The building was treated as one large single thermostatic zone that was controlled by one thermostat. What it was not designed to do was to compensate for the stack effect of the buoyant warm air that it generated. Warm air rises like smoke through a chimney stack, hence the term “stack effect.” With the enclosure of the stairwell, the various spaces served by the heating system were isolated floor by floor. From a heating perspective,

this trapped warm air at the ceiling level rather than permitting it to flow freely by natural buoyancy up the stairwell to the floors above. From a cooling perspective this eliminated the natural convective cooling generated by the air flow into the stairwell/atrium. The numerous additional mechanical cooling systems point towards both a shift in what was expected in terms of comfort and the fact that the natural ventilation system of the original construction no longer was deemed adequate.

The centralized nature of the original heating source for the first and second floors points to several potential opportunities to make the Fisher Mansion more energy efficient and, therefore, more sustainable:

1. *Non-residential HVAC system:* The existing HVAC system is the outgrowth of the original gravity fed warm air furnace system found on large residential buildings in the late-nineteenth century. Through the years various modifications and overlays that reflect the change in use from a single family dwelling to a convent and a halfway house have resulted in an agglomeration of several different systems. Investigation of conversion/replacement with a non-residentially oriented HVAC system is in order. There appears to be sufficient space in the basement to install a small multizone system that could serve all three floors individually as well as providing for multiple thermostatic zones on each floor. Further investigation is needed to determine if the original ductwork, at a minimum, could be isolated by floor and also be augmented by extending new ductwork to serve the third floor. In this fashion, the control of temperature, humidity, and air-filtration could be completed from one single heating/cooling source. This will also allow removal of the various evaporative coolers and window air-conditioners thereby reducing overall maintenance expenses (e.g., number of equipment locations, equipment obsolescence) and improving the visual appearance of the building. A local example of this can be found in several of the formerly residential buildings converted to office space at Fort Douglas.
2. *Ground-coupled heat pump:* Replace the existing heating source with a ground-coupled heat pump that can be used to seasonally provide heating or cooling as needed. The piping field needed to facilitate the ground source heat exchange could be located beneath the parking lot located just north of the Fisher Mansion using either a vertical configuration if geologic conditions allow or in a horizontal configuration otherwise. If a heat pump is installed, it could serve to heat and cool the building and thus eliminate the need for the various evaporative coolers and air-conditioning systems currently in place. The immediate adjacency of the Jordan River may also provide opportunities for seasonal heat exchanges.
3. *Digital controls:* Opportunities in this regard can range from simple time clock and programmable thermostats to a fully automated central digital control system located onsite that can be remotely accessed from a remote site if needed.
4. *Enthalpy economization:* The centralized air distribution network also allows for a digitally controlled monitoring system which compares the heat content of the outdoor air and automatically switches from mechanically cooled air to outdoor air when the outdoor is sufficiently cool to provide comfort cooling. The addition of an appropriately sized fresh air intake would need to be integrated into the existing system to accommodate the airflow requirements. This option would become more viable if a non-residential system has been installed to replace the existing system.

5. *Stairwell/atrium as solar chimney/stack ventilator:* As mentioned earlier, the enclosed stairwell/atrium could be reopened to allow air and light to pass through it. This introduces a disadvantage to the heating aspects since (if not adequately controlled) heated air in the winter would flow into the atrium and essentially be wasted. However, this reintroduces the natural cooling process of the original building design. In either case, the air flow would need to be controlled in some fashion. This can be accomplished by installing an appropriately fire-rated glass enclosure system in place of the gypsum wallboard partition and installing a thermostatically or digitally controlled exhaust system at the top of the stairwell/atrium. This strategy also opens the possibility for the use of “free cooling” in the summer by allowing the stairwell/atrium to act as a mechanism to relieve heat gains in the summer. In this scenario, cooler nighttime air is introduced into the building to flush out the accumulated heat gained during the day and is drawn upward by either natural convection or mechanical ventilation. The combination of the fresh outdoor air with the thermal mass of the exterior brick walls provides the catalyst for reducing the overall mechanical cooling needed during the daytime hours. The mechanical equipment for this integrated system could be located within the third floor space. By extension, the air exhausted from the top of the atrium could be used in a heat exchange system to preheat domestic hot water.
6. *Low profile paddle fans on the ceiling:* Due to the high ceilings found in the Fisher Mansion, heat rises above the occupied space year round. In the summer this is desirable, however, in winter that heat is better used within the occupied space. Consider installing a low profile paddle fan in each room. Careful attention needs to be made to not compromise the visual integrity of the space involved, especially those spaces that have an original period chandelier. This is achievable by selecting fans that do not project lower than the line of sight created by existing fixtures or visually intrude on the appearance of the chandeliers. Many fans of this type are reversible to enhance the movement of air upward or downward as seasonal needs warrant.
7. *Existing HVAC equipment tuning and calibration:* At a minimum, all HVAC equipment should be tested and tuned to optimize performance.
8. *Ductwork cleaning:* Where possible, the interior of the ductwork should be cleaned to remove accumulated dirt and other foreign materials.
9. *Fireplaces:* The existing fireplaces are character-defining features of the spaces where they are located. If future use is not feasible, seal the flues to eliminate air flow and prevent wasting heat. If further use is considered feasible, consider converting to a natural gas fuel source and integrate venting and combustion air intakes to a concealed location on the exterior of the building.
10. *Kitchen exhaust hood:* The commercial kitchen fume hood includes an industrial kitchen fan. Determine if future use is warranted. In not remove and block opening to reduce infiltration.

Lighting

Many of the light fixtures have already been updated with compact fluorescent lamps. Continued exercise of this strategy is encouraged, however, care must be taken to meet the actual lighting requirements of any new use of the interior spaces. The limited number of fixtures and their location (e.g., chandeliers and wall sconces) indicate the need for the use of supplemental lighting. The following considerations are advised for the new lighting system:

1. *Supplemental lighting:* While the existing light fixtures are part of the historic character defining features of the interior spaces (along with the ample daylighting), supplemental lighting could come in the form of desktop and other task lighting sources. Depending on the final use of the building, discreet track lighting and recessed lighting systems could be installed in the ceiling to meet lighting needs. A local example of this can be seen at the Chase Home Museum of Folk Art at Liberty Park that was a noted conversion of the Chase family house into an art gallery. Care should be used in sensitively installing the new wiring to service any new lighting systems. Surface mounted wiring should be avoided.
2. *Digital control:* Many of the lights are controlled manually and consideration should be given to installing a multi-signal occupancy sensor (e.g., a sensor that uses two or more inputs such as motion, infrared, and ultrasonic energy to determine occupancy). Exterior security lighting could be controlled by a two stage sensor that operates the light at a lower light output until activated by motion, infrared and ultrasonic detection whereupon the light comes to a full output state.

Utilities and Service Systems

The electrical system is comprised of a number of obsolete plug receptacles located in the baseboards. These receptacles do not include the contemporary third prong that is used to ground the device being plugged into them. Further investigation will be needed to determine if the Fisher Mansion has sufficient power circuits to supply adequate electricity for the intended use and whether expansion is possible.

The plumbing systems are of late-twentieth century manufacture and do not appear to include any of the more modern water-conserving toilets and faucets. Further investigation is needed into what the plumbing requirements will be for any new programmatic uses that are to be introduced. Only two fixtures in the Fisher Mansion appear to be of an appreciable age to merit consideration as a historic character defining feature. The pedestal sink in the first floor powder room adjacent to the door to the basement is made of enameled cast iron and is unique in the building. The service sink in the basement is the other potentially historic fixture. Note: this sink is served by a drum trap which is no longer allowed by code. In the closet at the top of the stairs on the third floor are the remains of some type of cistern system (i.e., metal tank with a float valve). Consideration for the reactivation of this cistern may provide opportunities for rainwater capture that can be used for irrigation of the grounds. Other sustainable measures would involve xeriscaping the grounds and/or installing drip irrigation systems.

Concluding Comment

The Fisher Mansion presents a number of opportunities as a demonstration of what can be accomplished when adaptively using an existing historic landmark for contemporary use. While the opportunities that affect the historic character defining features of the building must come under the review of the SLCHLC, this is not typically an onerous process if the selections of appropriately sensitive changes are considered. The key to a successful solution is to keep the various reviewing boards and constituencies informed along the decision making process. As the growing number of successfully adaptively used historic buildings grows both locally and nationally, this building once again provides the chance to demonstrate that preservation is an advanced sustainability strategy.

*These considerations were compiled by Robert A. Young, PE, Associate Professor and Historic Preservation Program Director at the University of Utah College of Architecture + Planning as a supplement to the historic structures report on the Fisher Mansion in Salt Lake City prepared as a service learning project for ARCH-6570 in partnership with the Salt Lake City Historic Landmarks Commission. For comments or further information contact him at (801) 581-3909 or via email at young@arch.utah.edu.